

# 7 Wiring diagrams

## 7 - 1 Wiring Diagrams - Single Phase

7

**VKM-GBM**

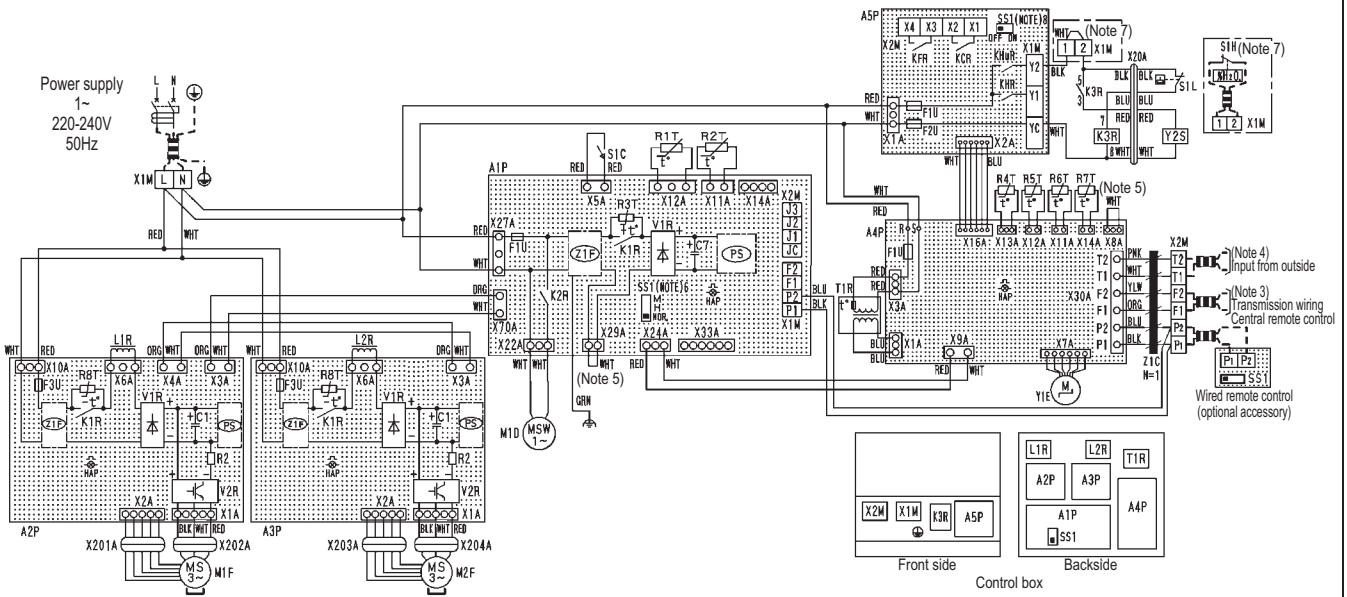

A1P	Printed circuit board	L2R	Reactor	X1M	Terminal block (power supply)
A2P	Printed circuit board (Exhaust fan)	M1D	Motor (damper motor)	X1M	Terminal block (power supply) (S1H)
A3P	Printed circuit board (Supply fan)	M1F	Motor (exhaust fan)	X2M	Terminal block (operation)
A4P	Printed circuit board	M2F	Motor (supply fan)	X1M, X2M	Terminal block (operation) (A1P)
A5P	Printed circuit board	PS	Switching power supply (A1P, A2P, A3P)	X1M, X2M	Terminal block (operation) (A5P)
C1	Capacitor (A2P, A3P)	R2	Resistor (A2P, A3P)	X20A	Relaying connector
C7	Capacitor (A1P)	R1T	Thermistor (indoor air)	X201A~X204A	Relaying connector
F1U	Fuse T, 6.3A, 250V (A1P)	R2T	Thermistor (outdoor air)	Y1E	Electronic expansion valve
F1U	Fuse Ⓞ, 5A, 250V (A4P)	R3T	Thermistor (PTC) (A1P)	Y2S	Solenoid valve for feed water
F1U, F2U	Fuse Ⓞ, 5A, 250V (A5P)	R4T	Thermistor (coil indoor air)	Z1C	Ferrite core
F3U	Fuse T, 6.3A, 250V (A2P, A3P)	R5T	Thermistor (coil liquid pipe)	Z1F	Noise filter (A1P, A2P, A3P)
HAP	Pilot lamp (service monitor-green) (A1P)	R6T	Thermistor (coil gas pipe)		Remote control
HAP	Pilot lamp (service monitor-green) (A2P, A3P)	R7T	Thermistor (coil outdoor air)	SS1	Selector switch (remote control)
HAP	Pilot lamp (service monitor-green) (A4P)	R8T	Thermistor (NTC) (A2P, A3P)		Local purchase
K1R	Magnetic relay (A1P, A2P, A3P)	S1C	Limit switch (damper motor)	S1H	Humidity controller
K2R	Magnetic relay	S1L	Float switch (humidification)		Connector for option (A1P)
K3R	Magnetic relay (S1L)	SS1	Selector switch (A1P)	X14A	Connector (CO <sub>2</sub> sensor)
KCR, KFR	Magnetic relay (A5P)	T1R	Transformer (220-240V/22V)	X33A	Connector (adapter for wiring)
KHR, KHuR	Magnetic relay (A5P)	V1R	Diode bridge (A1P, A2P, A3P)		
L1R	Reactor	V2R	Power module (A2P, A3P)		

**NOTES**

- Ⓞ, Ⓞ, Ⓞ : connector, □, □, □, □ : terminal, □ : short circuit connector
- : field wiring
- In case using central remote control, connect it to the unit in accordance with the attached manual.
- When connecting the input wires from outside, forced OFF or ON/OFF control operation can be selected by remote control. In details, refer to the installation manual attached to the unit.
- Do not remove short circuit connector of X8A (A4P), X29A (A1P). If removed, the unit will not work.
- SS1(A1P) has already been set to "NOR". At factory set, the unit will not work if the settings are changed.
- In case attached humidity controller, remove short circuit line of between X1M (1) and X1M(2).
- SS1(A5P) has already been set to "OFF". At factory set, humidifying becomes impossible, if the settings are changed.
- Symbols shown as follows  
BLK: BLACK, RED: RED, BLU: BLUE, WHT: WHITE, YLW: YELLOW, ORG: ORANGE, GRN: GREEN.