



Air Conditioning Technical Data RXF-D



TABLE OF CONTENTS

RXF-D

1	Features	4
	RXF-D	4
2	Specifications	5
3	Electrical data	12
4	Capacity tables	13
	Cooling Capacity Tables	13
5	Dimensional drawings	17
6	Centre of gravity	18
7	Piping diagrams	20
8	Wiring diagrams	22
	Wiring Diagrams - Single Phase	22
9	Sound data	25
	Sound Pressure Spectrum	25
10	Operation range	29

1 Features

1 - 1 RXF-D

- › Daikin outdoor units are neat, sturdy and can easily be mounted on a roof or terrace or simply placed against an outside wall
- › Daikin outdoor units are equipped with an anti-corrosion treated heat exchanger (blue fin) which ensures greater resistance to the most severe weather conditions
- › Outdoor units for pair application
- › Choosing for an R-32 product, reduces the environmental impact with 68% compared to R-410A and leads directly to lower energy consumption thanks to its high energy efficiency

1

Inverter

2 Specifications

2 - 1 Specifications

Technical specifications			FTXF20D + RXF20D	FTXF25D + RXF25D	FTXF35D + RXF35D	FTXF42D + RXF42D
Indoor unit			FTXF20D5V1B	FTXF25D5V1B	FTXF35D5V1B	FTXF42D5V1B
Outdoor unit			RXF20D5V1B	RXF25D5V1B	RXF35D5V1B	RXF42D5V1B
Cooling capacity	Min.	kW	1.3			1.4
	Min.	Btu/h	4,400.0			4,800.0
	Min.	kcal/h	1,118.0			1,204.0
	Nom.	kW	2.00	2.50	3.30	4.20
	Nom.	Btu/h	6,800.0	8,500.0	11,300	14,300
	Nom.	kcal/h	1,720.0	2,150.0	2,838.0	3,611.0
	Max.	kW	2.4	2.8	3.8	4.3
	Max.	Btu/h	8,200.0	9,600.0	12,800.0	14,700.0
	Max.	kcal/h	2,064.0	2,408.0	3,224.0	3,697.0
	Cooling capacity - Low sound mode (Stb. 2020, 189)	Min.	kcal/h	-		
Max.		kcal/h	-			-
Heating capacity	Min.	kW	1.30			1.40
	Min.	Btu/h	4,400.0			4,800.0
	Min.	kcal/h	1,118.0			1,204.0
	Nom.	kW	2.40	2.80	3.50	4.60
	Nom.	Btu/h	8,200.0	9,600.0	11,900	15,700
	Nom.	kcal/h	2,064.0	2,408.0	3,010.0	3,955.0
	Max.	kW	3.30	3.70	4.40	5.00
	Max.	Btu/h	11,300.0	12,600.0	15,000.0	17,100.0
	Max.	kcal/h	2,838.0	3,181.0	3,783.0	4,300.0
	Power input	Cooling	Min.	0.31		
Nom.			0.592	0.772	1.00	1.27
Max.			0.72	1.05	1.40	1.50
Heating		Min.	0.25			
		Nom.	0.640	0.750	0.940	1.24
		Max.	0.95	1.11	1.50	1.40
Nominal efficiency	EER		3.38	3.24		3.30
	COP		3.75	3.73		3.71
	Energy labeling Directive	Cooling Heating			A A	
Space cooling	Energy efficiency class		A++			
	Capacity Pdesign	kW	2.00	2.50	3.50	4.20
	SEER		6.50			
	Annual energy consumption	kWh/a	108	135	188	226
Space heating (Average climate)	Capacity Pdesign	kW	2.20	2.40	2.60	3.30
	Energy efficiency class		A+			
	SCOP/A		4.11			4.30
	SCOPnet/A		4.15		4.16	4.36
	Pdh Heating capacity at -10°	kW	1.91	2.00	2.22	2.61
	Annual energy consumption	kWh/a	749	818	885	1,075
	Required back up heating cap at design conditions	kW	0.290	0.400	0.380	0.690
	Space heating (Warm climate)	Capacity Pdesignh	kW	1.18	1.29	1.40
Energy efficiency class		A+++	A++		A+++	
SCOP			5.20	5.00	4.87	5.35
SCOPnet			5.28	5.26	5.13	5.72
Annual energy consumption		kWh/a	321	361	402	466
Required back up heating cap at design conditions		kW	0.00			
Space cooling	A Condi- Pdc	kW	2.00	2.50	3.50	4.20
	tion (35°C EERd		3.35	3.30	3.10	3.30
	- 27/19) Power input	kW	0.597	0.758	1.13	1.27
	B Condi- Pdc	kW	1.47	1.84	2.58	3.09
	tion (30°C EERd		5.10	4.91	4.64	4.70
	- 27/19) Power input	kW	0.288	0.375	0.556	0.657
	C Condi- Pdc	kW	0.950	1.18	1.66	1.99
	tion (25°C EERd		8.52	8.41	8.55	7.91
	- 27/19) Power input	kW	0.112	0.140	0.194	0.252
	D Condi- Pdc	kW		1.25		1.35
tion (20°C EERd			11.7		12.8	
- 27/19) Power input	kW		0.107		0.105	

2 Specifications

2 - 1 Specifications

Technical specifications					FTXF20D + RXF20D	FTXF25D + RXF25D	FTXF35D + RXF35D	FTXF42D + RXF42D			
Space heating (Average climate)	TOL	Tol (temperature operating limit) °C			-15						
		Pdh (declared heating cap) kW				1.71		2.05	2.10		
		COPd (declared COP)				2.47		2.02	2.06		
			Power input kW				0.692	1.01	1.02		
	TBivalent	Tbiv (bivalent temperature) °C			-7.0						
		Pdh (declared heating cap) kW				1.95	2.12	2.30	2.92		
		COPd (declared COP)				2.78	2.75		2.70		
		Power input kW				0.701	0.771	0.875	1.08		
	A Con- dition (-7°C)	Pdh (declared heating cap) kW				1.95	2.12	2.30	2.92		
		COPd (declared COP)				2.78	2.75		2.70		
		Power input kW				0.701	0.771	0.875	1.08		
	B Condi- tion (2°C)	Pdh (declared heating cap) kW				1.18	1.29	1.40	1.78		
Space heating (Average climate)	B Condi- tion (2°C)	COPd (declared COP)			4.11						
		Power input kW				0.287	0.314	0.338	0.408		
	C Condi- tion (7°C)	Pdh (declared heating cap) kW			0.900						
		COPd (declared COP)			5.15						
		Power input kW				0.175		0.185	0.207		
	D Con- dition (12°C)	Pdh (declared heating cap) kW			1.00						
		COPd (declared COP)			6.57						
		Power input kW				0.152		0.121	0.155		
Space heating (Warm climate)	TOL	Tol (temperature operating limit) °C			-15						
		Pdh (declared heating cap) kW				1.71		2.05	2.10		
		COPd (declared COP)				2.47		2.02	2.06		
		Power input kW				0.692		1.01	1.02		
	TBivalent	Tbiv (bivalent temperature) °C			2						
		Pdh (declared heating cap) kW				1.18	1.29	1.40	1.78		
		COPd (declared COP)				4.17	4.11	4.13	4.36		
		Power input kW				0.283	0.314	0.339	0.408		
	B Condi- tion (2°C)	Pdh (declared heating cap) kW				1.18	1.29	1.40	1.78		
		COPd (declared COP)				4.17	4.11	4.14	4.36		
		Power input kW				0.283	0.314	0.338	0.408		
	C Condi- tion (7°C)	Pdh (declared heating cap) kW			0.900						
		COPd (declared COP)			5.08						
		Power input kW				0.177	0.175	0.185	0.207		
	D Con- dition (12°C)	Pdh (declared heating cap) kW			1.00						
		COPd (declared COP)			7.06						
		Power input kW				0.142	0.152	0.121	0.155		
	Power consump- tion in other than active mode	Crank- case heater mode	PCK W			0.00					
			Off mode POFF W			1.00					
		Standby mode	Cooling PSB W			1.00					
			Heating PSB W			1.0					
		Thermo- stat-off mode	PTO	Cooling W				23	24	29	40
				Heating W				23		29	40
	Cooling	Cdc (Degradation cooling)			0.25						
Heating	Cdh (Degradation heating)			0.25							
Cooling function included					Yes						
Heating function included					Yes						
Average climate included					Yes						
Cold season included					No						
Warm season included					Yes						
Ecolabel logo					No	Yes		No			
Eurovent	Sound power level outdoor	Cooling	Nom.	dBa	60			61			
		Cooling	Nom.	dBa	53	54		59			
	Piping length	Cooling	Measuring con- dition	m	5.0						

Technical specifications					FTXF50D + RXF50D	FTXF60D + RXF60D	FTXF71D + RXF71D
Indoor unit					FTXF50D2V1B	FTXF60D2V1B	FTXF71D2V1B
Outdoor unit					RXF50D5V1B	RXF60D5V1B	RXF71D5V1B

2 Specifications

2 - 1 Specifications

Technical specifications			FTXF50D + RXF50D	FTXF60D + RXF60D	FTXF71D + RXF71D	
Cooling capacity	Min.	kW	1.70		2.30	
	Min.	Btu/h	5,800		7,800	
	Min.	kcal/h	1,462		1,978	
	Nom.	kW	5.00	6.00	7.10	
	Nom.	Btu/h	17,100	20,500	24,200	
	Nom.	kcal/h	4,299	5,159	6,105	
	Max.	kW	6.00	7.00	7.30	
	Max.	Btu/h	20,500	23,900	24,900	
Max.	kcal/h	5,159	6,019	6,277		
Cooling capacity - Low sound mode (Stb. 2020, 189)	Min.	kcal/h	-			
	Max.	kcal/h	-			
Heating capacity	Min.	kW	1.70		2.30	
	Min.	Btu/h	5,800		7,800	
	Min.	kcal/h	1,500		2,000	
	Nom.	kW	6.00	6.40	8.20	
	Nom.	Btu/h	20,500	21,800	28,000	
	Nom.	kcal/h	5,159	5,503	7,051	
	Max.	kW	7.70	8.00	9.00	
	Max.	Btu/h	26,300	27,300	30,700	
Max.	kcal/h	6,621	6,879	7,739		
Power input	Cooling Nom.	kW	1.50	1.85	2.77	
	Heating Nom.	kW	1.62	1.63	2.21	
Nominal efficiency	EER		3.33	3.25	2.56	
	COP		3.71	3.93	3.15	
	Annual energy consumption	kWh	751	923	1,387	
	Energy labeling Directive	Cooling Heating	A		E	
Space cooling	Energy efficiency class		A++		A	
	Capacity Pdesign	kW	5.00	6.00	7.10	
	SEER		6.21	6.15	5.15	
	Annual energy consumption	kWh/a	282	342	483	
Space heating (Average climate)	Capacity Pdesign	kW	4.60	4.80	6.20	
	Energy efficiency class		A+		A	
	SCOP/A		4.06		3.81	
Space heating (Average climate)	SCOPnet/A		4.09		3.84	
	Pdh Heating capacity at -10°	kW	4.07	4.24	5.02	
	Annual energy consumption	kWh/a	1,585	1,654	2,275	
	Required back up heating cap at design conditions	kW	0.53	0.56	1.18	
Space heating (Warm climate)	Capacity Pdesignh	kW	2.48	2.59	3.34	
	Energy efficiency class		A+++			
	SCOP		5.31	5.17	5.23	
	SCOPnet		5.39	5.24	5.29	
	Annual energy consumption	kWh/a	654	702	894	
	Required back up heating cap at design conditions	kW		0.00		
Space cooling	A Condi- tion (35°C - 27/19)	Pdc EERd Power input	kW	5.00 3.33 1.50	6.00 3.25 1.85	7.10 2.56 2.77
	B Condi- tion (30°C - 27/19)	Pdc EERd Power input	kW	3.69 4.67 0.79	4.43 4.17 1.06	5.24 3.98 1.32
	C Condi- tion (25°C - 27/19)	Pdc EERd Power input	kW	2.37 6.92 0.34	2.85 7.21 0.40	3.37 6.14 0.55
	D Condi- tion (20°C - 27/19)	Pdc EERd Power input	kW	2.12 11.68 0.18	2.39 12.05 0.20	2.60 8.11 0.32

2 Specifications

2 - 1 Specifications

Technical specifications				FTXF50D + RXF50D	FTXF60D + RXF60D	FTXF71D + RXF71D	
Space heating (Average climate)	TOL	Tol (temperature operating limit) °C		-15			
		Pdh (declared heating cap) kW	4.07	4.22	4.24		
		COPd (declared COP)	2.06	2.33	2.24		
	TBivalent	Power input kW		1.98	1.81	1.89	
		Tbiv (bivalent temperature) °C			-7		
			Pdh (declared heating cap) kW	4.07	4.25	5.49	
	COPd (declared COP)		2.71	2.22			
	A Con- dition (-7°C)	Power input kW		1.50	1.91	2.47	
		Pdh (declared heating cap) kW	4.07	4.25	5.49		
		COPd (declared COP)	2.71	2.22			
	B Condi- tion (2°C)	Power input kW		1.50	1.91	2.47	
		Pdh (declared heating cap) kW	2.48	2.59	3.34		
COPd (declared COP)		3.98	4.28	3.91			
C Condi- tion (7°C)	Power input kW		0.62	0.61	0.85		
	Pdh (declared heating cap) kW	1.60	1.67	2.15			
Space heating (Average climate)	C Condi- tion (7°C)	COPd (declared COP)		5.13	5.24	4.72	
		Power input kW		0.31	0.32	0.46	
	D Con- dition (12°C)	Pdh (declared heating cap) kW		1.79	2.03	1.55	
		COPd (declared COP)		6.91	6.41	6.74	
	Power input kW		0.26	0.32	0.23		
	Space heating (Warm climate)	TOL	Tol (temperature operating limit) °C		-15		
Pdh (declared heating cap) kW			4.07	4.22	4.24		
COPd (declared COP)			2.06	2.33	2.24		
TBivalent		Power input kW		1.98	1.81	1.89	
		Tbiv (bivalent temperature) °C			2		
			Pdh (declared heating cap) kW	2.48	2.59	3.34	
COPd (declared COP)			3.98	4.28	3.91		
B Condi- tion (2°C)		Power input kW		0.62	0.61	0.85	
		Pdh (declared heating cap) kW	2.48	2.59	3.34		
		COPd (declared COP)	3.98	4.28	3.91		
C Condi- tion (7°C)		Power input kW		0.62	0.61	0.85	
		Pdh (declared heating cap) kW	1.60	1.67	2.15		
		COPd (declared COP)	5.13	5.24	4.72		
D Con- dition (12°C)		Power input kW		0.31	0.32	0.46	
		Pdh (declared heating cap) kW	1.79	2.03	1.55		
		COPd (declared COP)	6.91	6.41	6.74		
Power input kW		0.26	0.32	0.23			
Power consump- tion in other than active mode		Crank- case heater mode	PCK W		0		
	Off mode POFF W		1				
	Standby mode	Cooling PSB W	1				
		Heating PSB W	1				
	Thermo- stat-off mode	PTO Cooling W	12		14		
		Heating W	13		14		
Cooling	Cdc (Degradation cooling)			0.25			
Heating	Cdh (Degradation heating)			0.25			
Cooling function included				Yes			
Heating function included				Yes			
Average climate included				Yes			
Cold season included				No			
Warm season included				Yes			
Eurovent	Sound power level outdoor	Cooling	Nom.	dBa	61	63	66
		Cooling	Nom.	dBa	59	60	62
Eurovent	Piping length	Cooling	Measuring con- dition	m	5.00		

Electrical specifications				FTXF20D + RXF20D	FTXF25D + RXF25D	FTXF35D + RXF35D	FTXF42D + RXF42D	FTXF50D + RXF50D	FTXF60D + RXF60D
Power factor	Nominal	Cooling	%	-				94.60	99.10
		Heating	%	-				96.30	98.30

2 Specifications

2 - 1 Specifications

Electrical specifications				FTXF20D + RXF20D	FTXF25D + RXF25D	FTXF35D + RXF35D	FTXF42D + RXF42D	FTXF50D + RXF50D	FTXF60D + RXF60D
Current	Nominal running current (RLA)	Cooling	A			-		6.90	8.10
	Nominal running current (RLA) - 50Hz	Heating	A			-		7.30	7.20
Current - 50Hz	Maximum fuse amps (MFA)		A			-		20.00	

Electrical specifications				FTXF71D + RXF71D					
Power factor	Nominal	Cooling	%						98.80
		Heating	%						98.40
Current	Nominal running current (RLA)	Cooling	A						12.20
		Heating	A						11.50
Current - 50Hz	Maximum fuse amps (MFA)		A						20.00

Nominal cooling capacities are based on: indoor temperature: 27°CDB, 19°CWB, outdoor temperature: 35°CDB, equivalent refrigerant piping: 5m, level difference: 0m. Data for high efficiency series, Eurovent certified |

Nominal cooling capacities are based on: indoor temperature: 27°CDB, 19°CWB, outdoor temperature: 35°CDB, equivalent refrigerant piping: 5m, level difference: 0m. |

Nominal heating capacities are based on: indoor temperature: 20°CDB, outdoor temperature: 7°CDB, 6°CWB, equivalent refrigerant piping: 5m, level difference: 0m. Data for standard efficiency series |

Nominal heating capacities are based on: indoor temperature: 20°CDB, outdoor temperature: 7°CDB, 6°CWB, equivalent refrigerant piping: 5m, level difference: 0m. |

See separate drawing for operation range |

See separate drawing for electrical data

Technical Specifications				RXF20D	RXF25D	RXF35D	RXF42D		
Casing	Colour			Ivory white					
Dimensions	Unit	Height	mm	550					
		Width	mm	658					
		Depth	mm	275					
	Packed unit	Height	mm	630					
		Width	mm	790					
		Depth	mm	400					
Weight	Unit	kg		24.0		28.0			
	Packed unit	kg		26		30			
Packing	Weight		kg	2					
Heat exchanger	Length			mm	670		647		
	Rows	Quantity			1		2		
		Fin pitch			mm	1.40			
	Stages			Quantity	24				
	Tube type				ø7 Hi-XD				
	Tube material				Copper				
	Fin Type				Waffle Hydrophilic Blue				
	Fan	Type			Propeller				
		Air flow rate	Cooling	High	m ³ /min	27.6		29.0	28.5
cfm				975		1,024	1,006		
Heating		High	m ³ /min	27.1		28.0	27.5		
	cfm	957		990	971				
Fan motor	Model			DFC04A1VA				ZWA138S28A	
	Insulation grade			Class "E"					
	Output			W				26	
	Speed	Cooling	High	rpm	840		900		
			Low	rpm			700		
Heating	High	rpm	870		900				
	Low	rpm			720				
Compressor	Model			1Y078BKAX1P#D				1YC25KXD#D	
	Oil Amount			cm ³				400	375
	Type				Hermetically sealed swing compressor				
	Output			W				870.0	
	Oil Type				FW68DA				
Operation range	Cooling	Ambient	Min.	°CDB				-10	
			Max.	°CDB				48	
Operation range	Heating	Ambient	Min.	°CWB				-15	
				°CDB				-15	
			Max.	°CWB				18	
				°CDB				24	
Sound power level	Heating	Nom.	dBA	60.0		62.0			
Sound pressure level	Cooling	High	dBA	46.0		48.0			
	Heating	High	dBA	47.0		48.0			
Refrigerant	Type			R-32					
	Charge			kg		0.450	0.550	0.750	
	GWP			675.0					

2 Specifications

2 - 1 Specifications

2

Technical Specifications				RXF20D	RXF25D	RXF35D	RXF42D
Piping connections	Liquid	OD	mm	6			
	Gas	OD	mm	9.50			
	Drain	OD	mm	18			
	Piping length	OU - IU	Max. m	20			
	Additional refrigerant charge			kg/m	0.02 (for piping length exceeding 10m)		
	Level difference	IU - OU	Max. m	12.0			
Capacity control	Method			Variable (inverter)			

Technical Specifications				RXF50D	RXF60D	RXF71D	
Casing	Colour			Ivory white			
Dimensions	Unit	Height	mm	734			
		Width	mm	870			
		Depth	mm	373			
	Packed unit	Height	mm	820			
		Width	mm	1,050			
		Depth	mm	480			
Weight	Unit	kg		46.0	50.0		
	Packed unit	kg		50.0	54.0		
Packing	Weight		kg	4.0			
Heat exchanger	Length			mm	943	920	
	Rows	Quantity			1	2	
	Fin pitch			mm	1.4		
	Stages			Quantity	32		
	Passes			Quantity	2.0		
	Tube type			ø7 Hi-XD			
	Fin	Type			Waffle fin (PE)		
	Fan	Type			Propeller fan		
Air flow rate	Cooling	Nom.	m ³ /min	43.2	47.8		
			cfm	1,527	1,689		
	Heating	Nom.	m ³ /min	43.2	45.3		
			cfm	1,527	1,600		
Fan motor	Model			D55F-31			
	Output			W	58	81	
	Speed	Cooling	High	rpm	740	760	
			Nom.	rpm	710	740	
			Low	rpm	710	740	
		Heating	High	rpm	710	660	
			Nom.	rpm	710	660	
			Low	rpm	630	660	
Compressor	Model			2YC40JXD#C			
	Oil Amount			cm ³	650		
	Type			Hermetically sealed swing compressor			
	Output			W	1,300.0		
Sound power level	Heating			Nom. dBA	61	63	65
	Cooling			Nom. dBA	47	49	52
	Heating			Nom. dBA	49		52
	Refrigerant	Type			R-32		
Charge			kg	0.90	1.15		
GWP			675				
Piping connections	Liquid	OD	mm	6.35			
	Gas	OD	mm	12.7			
	Drain	OD	mm	16			
	Piping length	OU - IU	Max. m	30			
	Additional refrigerant charge			kg/m	0.02 (for piping length exceeding 10m)		
	Level difference	IU - OU	Max. m	20			
	Heat insulation			Both liquid and gas pipes			
	Capacity control	Method			Variable (inverter)		

Standard accessories: Installation manual;Quantity: 1;

Standard accessories: Drain plug;Quantity: 1;

Standard accessories: Refrigerant charge label;Quantity: 1;

Standard accessories: Multilingual fluorinated greenhouse gases labels;Quantity: 1;

Standard accessories: General safety precautions;Quantity: 1;

Standard accessories: Drain cap (1);Quantity: 6;

Standard accessories: Drain cap (2);Quantity: 3;

2 Specifications

2 - 1 Specifications

Electrical Specifications			RXF20D	RXF25D	RXF35D	RXF42D	RXF50D	RXF60D	RXF71D
Power supply	Phase		1~						
	Frequency	Hz	50						
	Voltage	V	220-240						
Wiring connections	For power supply	Quantity	3						
		Remark	Earth wire included						
	For connection with indoor	Quantity	4						
		Remark	Earth wire included						
Current - 50Hz	Maximum fuse amps (MFA)	A	16					-	

See separate drawing for operation range |
 See separate drawing for electrical data |
 Contains fluorinated greenhouse gases

3 Electrical data

3 - 1 Electrical Data

3

ARXF-D RXF20-42D

Unit combination restrictions		Power supply				COMP		OFM		IFM		
Indoor unit	Outdoor unit	Hz	Voltage	Voltage range	MCA	MFA	RHz	RLA	kW	FLA	kW	FLA
FTXF20D5V1B	RXF20D5V1B	50	220	Maximum -50-Hz :264-V Minimum -50-Hz :198-V	8,02	16	39,0	3,2	0,024	0,171	0,029	0,41
		50	230					3,4				
		50	240					3,2				
FTXF25D5V1B	RXF25D5V1B	50	220	Maximum -50-Hz :264-V Minimum -50-Hz :198-V	8,09	16	54,0	3,5	0,033	0,235	0,029	0,41
		50	230					3,6				
		50	240					3,5				
FTXF35D5V1B	RXF35D5V1B	50	220	Maximum -50-Hz :264-V Minimum -50-Hz :198-V	9,30	16	70,0	4,5	0,033	0,235	0,037	0,52
		50	230					4,7				
		50	240					4,5				
FTXF42D5V1B	RXF42D5V1B	50	220	Maximum -50-Hz :264-V Minimum -50-Hz :198-V	9,38	16	78,0	5,5	0,030	0,229	0,050	0,60
		50	230					5,6				
		50	240					5,4				
ATXF20D5V1B	ARXF20D5V1B	50	220	Maximum -50-Hz :264-V Minimum -50-Hz :198-V	8,02	16	39,0	3,2	0,024	0,171	0,029	0,41
		50	230					3,4				
		50	240					3,2				
ATXF25D5V1B	ARXF25D5V1B	50	220	Maximum -50-Hz :264-V Minimum -50-Hz :198-V	8,09	16	54,0	3,5	0,033	0,235	0,029	0,41
		50	230					3,6				
		50	240					3,5				
ATXF35D5V1B	ATXF35D5V1B	50	220	Maximum -50-Hz :264-V Minimum -50-Hz :198-V	9,30	16	70,0	4,5	0,033	0,235	0,037	0,52
		50	230					4,7				
		50	240					4,5				
ATXF42D5V1B	ATXF42D5V1B	50	220	Maximum -50-Hz :264-V Minimum -50-Hz :198-V	9,38	16	78,0	5,5	0,030	0,229	0,050	0,60
		50	230					5,6				
		50	240					5,4				

Notes

- 1) The ·RLA· is based on the following conditions.
Outdoor temperature ·35·°C DB
Indoor temperature ·27·°C DB / ·19·°C WB
- 2) Select the wire size according to the MCA.
- 3) The maximum allowable voltage that is unbalanced between phases is ·2·%.
- 4) Use a circuit breaker instead of a fuse.

Symbols

- MCA: Minimum Circuit Ampere [A]
- MFA: Maximum Fuse Ampere [A]
- RLA: Rated load amps [A]
- OFM: Outdoor fan motor
- IFM: Indoor fan motor
- RHz: Rated operating frequency [Hz]
- FLA: Full Load Ampere [A]
- kW: Fan motor rated output [kW]

3D137925

RXF50-71D

Unit combination restrictions		Power supply				COMP		OFM		IFM		
Indoor unit	Outdoor unit	Hz	Voltage	Voltage range	MCA	MFA	RHz	RLA	kW	FLA	kW	FLA
FTXF50A2V1B	RXF50B5V1B	50	220	Maximum -50-Hz :264-V Minimum -50-Hz :198-V	14,5	20	54	7,1	0,068	0,34	0,045	0,43
		50	230					6,9				
		50	240					6,8				
FTXF60A2V1B	RXF60B5V1B	50	220	Maximum -50-Hz :264-V Minimum -50-Hz :198-V	15,7	20	66	8,2	0,068	0,34	0,049	0,46
		50	230					8,1				
		50	240					8,0				
FTXF71A2V1B	RXF71A5V1B	50	220	Maximum -50-Hz :264-V Minimum -50-Hz :198-V	15,7	20	84	12,3	0,068	0,34	0,049	0,46
		50	230					12,2				
		50	240					12,1				
ATXF50A2V1B	ARXF50A5V1B	50	220	Maximum -50-Hz :264-V Minimum -50-Hz :198-V	14,5	20	54	7,1	0,068	0,34	0,045	0,43
		50	230					6,9				
		50	240					6,8				
ATXF60A2V1B	ARXF60A5V1B	50	220	Maximum -50-Hz :264-V Minimum -50-Hz :198-V	15,7	20	66	8,2	0,068	0,34	0,049	0,46
		50	230					8,1				
		50	240					8,0				
ATXF71A2V1B	ARXF71A5V1B	50	220	Maximum -50-Hz :264-V Minimum -50-Hz :198-V	15,7	20	84	12,3	0,068	0,34	0,049	0,46
		50	230					12,2				
		50	240					12,1				
FTXF50D2V1B	RXF50D5V1B	50	220	Maximum -50-Hz :264-V Minimum -50-Hz :198-V	14,5	20	54	7,1	0,068	0,34	0,045	0,43
		50	230					6,9				
		50	240					6,8				
FTXF60D2V1B	RXF60D5V1B	50	220	Maximum -50-Hz :264-V Minimum -50-Hz :198-V	15,7	20	66	8,2	0,068	0,34	0,049	0,46
		50	230					8,1				
		50	240					8,0				
FTXF71D2V1B	RXF71D5V1B	50	220	Maximum -50-Hz :264-V Minimum -50-Hz :198-V	15,7	20	84	12,3	0,068	0,34	0,049	0,46
		50	230					12,2				
		50	240					12,1				

SYMBOLS

- MCA : Minimum Circuit Ampere [A]
- MFA : Maximum Fuse Ampere [A]
- RLA : Rated load amps [A]
- OFM : Outdoor fan motor
- IFM : Indoor fan motor
- RHz : Rated operating frequency [Hz]
- FLA : Full Load Ampere [A]
- kW : Fan motor rated output [kW]

NOTES

1. The RLA is based on the following conditions.
 - Outdoor temperature ·35·°C DB
 - Indoor temperature ·27·°C DB / ·19·°C WB
2. Select the wire size according to the MCA.
3. The maximum allowable voltage that is unbalanced between phases is ·2·%.
4. Use a circuit breaker instead of a fuse.

3D133818A

4 Capacity tables

4 - 1 Cooling Capacity Tables

4

FTXF20D / RXF20D

ATXF20D / ARXF20D

Cooling · 220-240V 50Hz·

AFR	9,7
BF	0,22

Indoor air temperature [°C WB]	Indoor air temperature [°C DB]	Outdoor air temperature [°C DB]																	
		20			25			30			32			35			40		
		TC	SHC	PI	TC	SHC	PI	TC	SHC	PI	TC	SHC	PI	TC	SHC	PI	TC	SHC	PI
14	20	2,05	1,80	0,48	1,96	1,76	0,52	1,86	1,72	0,56	1,83	1,70	0,57	1,77	1,67	0,59	1,68	1,63	0,63
16	22	2,14	1,77	0,48	2,05	1,73	0,52	1,95	1,69	0,55	1,92	1,68	0,57	1,86	1,65	0,59	1,77	1,61	0,63
18	25	2,23	1,89	0,48	2,14	1,86	0,52	2,05	1,82	0,56	2,01	1,81	0,57	1,95	1,78	0,59	1,86	1,75	0,63
19	27	2,28	2,03	0,48	2,19	2,00	0,52	2,09	1,96	0,56	2,06	1,95	0,57	2,00	1,93	0,59	1,91	1,89	0,63
22	30	2,42	1,97	0,49	2,32	1,94	0,53	2,23	1,91	0,57	2,19	1,90	0,58	2,14	1,88	0,60	2,05	1,85	0,64
24	32	2,51	1,93	0,49	2,42	1,91	0,53	2,32	1,88	0,57	2,29	1,87	0,58	2,23	1,85	0,60	2,14	1,82	0,64

Heating · 220-240V 50Hz·

AFR	10,1
-----	------

Indoor air temperature [°C DB]	Outdoor air temperature [°C DB]											
	-15		-10		-5		0		6		10	
	TC	PI	TC	PI	TC	PI	TC	PI	TC	PI	TC	PI
15	1,19	0,41	1,43	0,42	1,67	0,44	1,92	0,60	2,56	0,63	2,81	0,65
20	1,12	0,42	1,36	0,43	1,60	0,47	1,84	0,61	2,50	0,64	2,73	0,66
22	1,09	0,42	1,33	0,44	1,57	0,47	1,81	0,61	2,47	0,65	2,69	0,67
24	1,06	0,42	1,30	0,44	1,54	0,48	1,78	0,63	2,43	0,65	2,66	0,67
25	1,04	0,43	1,28	0,44	1,52	0,48	1,76	0,63	2,41	0,66	2,64	0,67
27	1,01	0,43	1,25	0,47	1,49	0,48	1,74	0,63	2,38	0,66	2,61	0,68

Heating capacity at nominal operating frequency, measured according to ·EN 14511·.

Notes

- The capacities are based on the following conditions:
Corresponding refrigerant piping length: ·5,0· m
Level difference: ·0· m
- The bold cells indicate the standard conditions.

Symbols

- TC: Total capacity [kW]
PI: Power input [kW]
SHC: Sensible heat capacity [kW]
AFR: Air flow rate [m³/min]
BF: Bypass factor

3D137908

FTXF25D / RXF25D

ATXF25D / ARXF25D

Cooling · 220-240V 50Hz·

AFR	9,9
BF	0,22

Indoor air temperature [°C WB]	Indoor air temperature [°C DB]	Outdoor air temperature [°C DB]																	
		20			25			30			32			35			40		
		TC	SHC	PI	TC	SHC	PI	TC	SHC	PI	TC	SHC	PI	TC	SHC	PI	TC	SHC	PI
14	20	2,56	2,08	0,62	2,44	2,03	0,67	2,33	1,97	0,73	2,28	1,95	0,75	2,21	1,92	0,78	2,10	1,86	0,83
16	22	2,68	2,05	0,61	2,56	1,99	0,67	2,44	1,94	0,72	2,40	1,92	0,75	2,33	1,89	0,78	2,21	1,84	0,84
18	25	2,79	2,17	0,61	2,68	2,12	0,67	2,56	2,07	0,72	2,51	2,06	0,75	2,44	2,03	0,78	2,33	1,98	0,84
19	27	2,85	2,31	0,61	2,73	2,27	0,67	2,62	2,22	0,72	2,57	2,20	0,75	2,50	2,18	0,78	2,38	2,13	0,84
22	30	3,02	2,24	0,63	2,91	2,20	0,68	2,79	2,16	0,74	2,74	2,14	0,76	2,67	2,12	0,79	2,56	2,08	0,84
24	32	3,14	2,19	0,62	3,02	2,15	0,67	2,90	2,12	0,73	2,86	2,10	0,76	2,79	2,08	0,79	2,67	2,04	0,85

Heating · 220-240V 50Hz·

AFR	10,3
-----	------

Indoor air temperature [°C DB]	Outdoor air temperature [°C DB]											
	-15		-10		-5		0		6		10	
	TC	PI	TC	PI	TC	PI	TC	PI	TC	PI	TC	PI
15	1,33	0,50	1,61	0,53	1,87	0,55	2,15	0,72	2,89	0,75	3,15	0,78
20	1,25	0,52	1,52	0,54	1,79	0,56	2,06	0,73	2,80	0,77	3,05	0,79
22	1,22	0,52	1,48	0,54	1,75	0,57	2,03	0,74	2,76	0,77	3,01	0,80
24	1,19	0,53	1,46	0,55	1,73	0,57	2,00	0,75	2,73	0,78	2,98	0,80
25	1,17	0,53	1,44	0,55	1,71	0,57	1,98	0,75	2,71	0,78	2,96	0,81
27	1,14	0,53	1,41	0,56	1,67	0,59	1,95	0,76	2,67	0,79	2,92	0,81

Heating capacity at nominal operating frequency, measured according to ·EN 14511·.

Notes

- The capacities are based on the following conditions:
Corresponding refrigerant piping length: ·5,0· m
Level difference: ·0· m
- The bold cells indicate the standard conditions.

Symbols

- TC: Total capacity [kW]
PI: Power input [kW]
SHC: Sensible heat capacity [kW]
AFR: Air flow rate [m³/min]
BF: Bypass factor

3D137904

4 Capacity tables

4 - 1 Cooling Capacity Tables

4

FTXF35D / RXF35D
ATXF35D / ARXF35D

Cooling · 220-240V 50Hz·

AFR	11,8
BF	0,23

Indoor air temperature [°C WB]	Indoor air temperature [°C DB]	Outdoor air temperature [°C DB]																	
		20			25			30			32			35			40		
		TC	SHC	PI	TC	SHC	PI	TC	SHC	PI	TC	SHC	PI	TC	SHC	PI	TC	SHC	PI
14	20	3,38	2,54	0,76	3,22	2,46	0,84	3,07	2,39	0,91	3,01	2,36	0,94	2,92	2,31	0,99	2,76	2,23	1,06
16	22	3,54	2,50	0,77	3,38	2,42	0,84	3,22	2,35	0,92	3,17	2,33	0,95	3,07	2,28	0,99	2,92	2,22	1,07
18	25	3,69	2,62	0,77	3,54	2,56	0,85	3,38	2,49	0,92	3,32	2,46	0,95	3,22	2,42	1,00	3,07	2,36	1,07
19	27	3,76	2,76	0,77	3,61	2,70	0,85	3,45	2,64	0,92	3,39	2,61	0,95	3,30	2,57	1,00	3,15	2,52	1,08
22	30	3,99	2,67	0,78	3,84	2,61	0,86	3,68	2,56	0,93	3,62	2,54	0,96	3,53	2,50	1,01	3,38	2,44	1,08
24	32	4,14	2,60	0,79	3,99	2,55	0,86	3,84	2,50	0,94	3,77	2,48	0,97	3,68	2,44	1,01	3,53	2,39	1,09

Heating · 220-240V 50Hz·

AFR	11,9
-----	------

Indoor air temperature [°C DB]	Outdoor air temperature [°C WB]											
	-15		-10		-5		0		6		10	
	TC	PI	TC	PI	TC	PI	TC	PI	TC	PI	TC	PI
15	1,66	0,60	2,00	0,63	2,34	0,67	2,69	0,87	3,62	0,92	3,94	0,95
20	1,57	0,62	1,90	0,65	2,24	0,68	2,58	0,90	3,50	0,94	3,82	0,97
22	1,52	0,63	1,86	0,66	2,20	0,69	2,54	0,90	3,45	0,94	3,77	0,98
24	1,48	0,63	1,82	0,67	2,15	0,70	2,49	0,91	3,40	0,95	3,72	0,99
25	1,46	0,64	1,79	0,67	2,14	0,70	2,48	0,92	3,38	0,96	3,69	0,99
27	1,42	0,64	1,76	0,68	2,09	0,71	2,43	0,92	3,33	0,97	3,65	1,00

Heating capacity at nominal operating frequency, measured according to ·EN 14511·.

Notes

- The capacities are based on the following conditions:
Corresponding refrigerant piping length: ·5,0· m
Level difference: ·0· m
- The bold cells indicate the standard conditions.

Symbols

- TC: Total capacity [kW]
PI: Power input [kW]
SHC: Sensible heat capacity [kW]
AFR: Air flow rate [m³/min]
BF: Bypass factor

3D137906

FTXF42D / RXF42D
ATXF42D / ARXF42D

Cooling · 220-240V 50Hz·

AFR	12,6
BF	0,23

Indoor air temperature [°C WB]	Indoor air temperature [°C DB]	Outdoor air temperature [°C DB]																	
		20			25			30			32			35			40		
		TC	SHC	PI	TC	SHC	PI	TC	SHC	PI	TC	SHC	PI	TC	SHC	PI	TC	SHC	PI
14	20	4,17	3,14	1,04	4,02	3,07	1,11	3,86	3,01	1,19	3,80	2,98	1,22	3,71	2,93	1,26	3,56	2,87	1,34
16	22	4,38	3,09	1,04	4,22	3,02	1,11	4,07	2,97	1,19	4,00	2,94	1,22	3,91	2,90	1,26	3,76	2,85	1,34
18	25	4,57	3,24	1,05	4,41	3,19	1,12	4,26	3,14	1,20	4,19	3,11	1,23	4,10	3,08	1,27	3,94	3,03	1,35
19	27	4,66	3,42	1,05	4,51	3,37	1,12	4,35	3,33	1,20	4,29	3,30	1,23	4,20	3,27	1,27	4,05	3,24	1,35
22	30	4,95	3,31	1,06	4,80	3,26	1,13	4,64	3,23	1,21	4,58	3,21	1,24	4,49	3,18	1,28	4,34	3,13	1,36
24	32	5,14	3,23	1,06	4,99	3,19	1,13	4,83	3,15	1,21	4,77	3,14	1,24	4,68	3,10	1,28	4,53	3,07	1,36

Heating · 220-240V 50Hz·

AFR	12,8
-----	------

Indoor air temperature [°C DB]	Outdoor air temperature [°C WB]											
	-15		-10		-5		0		6		10	
	TC	PI	TC	PI	TC	PI	TC	PI	TC	PI	TC	PI
15	2,18	0,79	2,63	0,83	3,08	0,88	3,54	1,15	4,76	1,21	5,18	1,25
20	2,06	0,82	2,50	0,86	2,94	0,90	3,39	1,19	4,60	1,24	5,02	1,28
22	2,00	0,83	2,44	0,87	2,89	0,91	3,34	1,19	4,53	1,24	4,95	1,29
24	1,95	0,83	2,39	0,88	2,83	0,92	3,27	1,20	4,47	1,25	4,89	1,31
25	1,92	0,84	2,35	0,88	2,81	0,92	3,26	1,21	4,44	1,27	4,85	1,31
27	1,87	0,84	2,31	0,90	2,75	0,94	3,19	1,21	4,38	1,28	4,80	1,32

Heating capacity at nominal operating frequency, measured according to ·EN 14511·.

Notes

- The capacities are based on the following conditions:
Corresponding refrigerant piping length: ·5,0· m
Level difference: ·0· m
- The bold cells indicate the standard conditions.

Symbols

- TC: Total capacity [kW]
PI: Power input [kW]
SHC: Sensible heat capacity [kW]
AFR: Air flow rate [m³/min]
BF: Bypass factor

3D137907

4 Capacity tables

4 - 1 Cooling Capacity Tables

FTXF50D / RXF50D

Cooling	50 Hz	230 V	AFR	16,8
			BF	0,27

Indoor temperature		Outdoor temperature [°C DB]																	
EWB	EDB	20			25			30			32			35			40		
°C	°C	TC	SHC	PI	TC	SHC	PI	TC	SHC	PI	TC	SHC	PI	TC	SHC	PI	TC	SHC	PI
14,0	20	5,12	3,71	1,15	4,89	3,59	1,27	4,66	3,47	1,37	4,56	3,42	1,42	4,42	3,35	1,48	4,19	3,24	1,59
16,0	22	5,35	3,64	1,16	5,12	3,53	1,27	4,89	3,42	1,37	4,79	3,38	1,43	4,65	3,31	1,49	4,42	3,20	1,60
18,0	25	5,58	3,80	1,16	5,35	3,70	1,28	5,12	3,59	1,38	5,02	3,55	1,43	4,88	3,49	1,49	4,65	3,39	1,61
19,0	27	5,70	3,99	1,17	5,47	3,89	1,28	5,23	3,79	1,38	5,14	3,75	1,44	5,00	3,70	1,50	4,77	3,60	1,61
22,0	30	6,04	3,85	1,18	5,81	3,76	1,29	5,58	3,67	1,39	5,49	3,63	1,44	5,35	3,58	1,51	5,11	3,50	1,62
24,0	32	6,27	3,74	1,19	6,04	3,66	1,30	5,81	3,58	1,40	5,72	3,55	1,45	5,58	3,50	1,51	5,34	3,42	1,63

Heating	50 Hz	230 V	AFR	17,3
---------	-------	-------	-----	------

Indoor temperature		Outdoor temperature [°C WB]											
EDB		-15		-10		-5		0		6		10	
°C		TC	PI	TC	PI	TC	PI	TC	PI	TC	PI	TC	PI
15,0		2,86	1,04	3,43	1,10	4,01	1,15	4,58	1,51	6,21	1,58	6,75	1,64
20,0		2,68	1,07	3,26	1,13	3,83	1,18	4,41	1,54	6,00	1,62	6,54	1,67
22,0		2,61	1,09	3,19	1,14	3,76	1,19	4,34	1,56	5,92	1,63	6,46	1,69
24,0		2,54	1,10	3,12	1,15	3,69	1,20	4,27	1,57	5,83	1,65	6,38	1,70
25,0		2,51	1,10	3,08	1,16	3,66	1,21	4,23	1,58	5,79	1,65	6,33	1,71
27,0		2,43	1,11	3,01	1,17	3,59	1,22	4,17	1,59	5,71	1,67	6,25	1,72

Symbols

- AFR : Air flow rate [m³/min]
- BF : Bypass factor
- EWB : Entering wet-bulb temperature (°C WB)
- EDB : Entering dry-bulb temperature (°C DB)
- TC : Total capacity [kW]
- SHC : Sensible heat capacity [kW]
- PI : Power input [kW]

Notes

1. The ratings shown are net capacities which include a deduction for indoor fan motor heat.
2. The bold cells indicate the standard conditions.
Rated operating frequency [Hz]
3. The capacities are based on the following conditions:
Corresponding refrigerant piping length: 5 m
Level difference: 0m
4. The air flow rate and bypass factor are mentioned in the table.

3D113930B

FTXF60D / RXF60D

Cooling	50 Hz	230 V	AFR	17,3
			BF	0,27

Indoor temperature		Outdoor temperature [°C DB]																	
EWB	EDB	20			25			30			32			35			40		
°C	°C	TC	SHC	PI	TC	SHC	PI	TC	SHC	PI	TC	SHC	PI	TC	SHC	PI	TC	SHC	PI
14,0	20	6,15	4,35	1,42	5,87	4,20	1,55	5,59	4,05	1,69	5,48	4,00	1,74	5,31	3,91	1,83	5,03	3,77	1,97
16,0	22	6,42	4,27	1,43	6,14	4,13	1,56	5,86	4,00	1,70	5,75	3,94	1,76	5,59	3,86	1,83	5,31	3,73	1,97
18,0	25	6,70	4,44	1,44	6,42	4,31	1,58	6,14	4,18	1,71	6,03	4,13	1,77	5,86	4,05	1,85	5,58	3,93	1,98
19,0	27	6,84	4,65	1,44	6,56	4,52	1,58	6,28	4,40	1,71	6,17	4,35	1,77	6,00	4,28	1,85	5,72	4,16	1,99
22,0	30	7,25	4,47	1,45	6,97	4,36	1,59	6,69	4,25	1,72	6,58	4,21	1,78	6,41	4,14	1,86	6,14	4,04	2,00
24,0	32	7,53	4,34	1,46	7,25	4,24	1,60	6,97	4,14	1,73	6,86	4,10	1,79	6,69	4,04	1,87	6,41	3,94	2,00

Heating	50 Hz	230 V	AFR	17,9
---------	-------	-------	-----	------

Indoor temperature		Outdoor temperature [°C WB]											
EDB		-15		-10		-5		0		6		10	
°C		TC	PI	TC	PI	TC	PI	TC	PI	TC	PI	TC	PI
15,0		3,04	1,05	3,67	1,11	4,28	1,16	4,89	1,51	6,62	1,60	7,20	1,65
20,0		2,86	1,08	3,47	1,13	4,09	1,18	4,70	1,55	6,40	1,63	6,98	1,68
22,0		2,79	1,09	3,40	1,14	4,01	1,20	4,63	1,56	6,31	1,65	6,89	1,70
24,0		2,71	1,10	3,33	1,16	3,94	1,21	4,55	1,58	6,23	1,66	6,80	1,71
25,0		2,67	1,11	3,28	1,16	3,90	1,22	4,52	1,59	6,18	1,66	6,76	1,72
27,0		2,60	1,11	3,21	1,17	3,82	1,22	4,43	1,60	6,09	1,68	6,67	1,73

Symbols

- AFR : Air flow rate [m³/min]
- BF : Bypass factor
- EWB : Entering wet-bulb temperature (°C WB)
- EDB : Entering dry-bulb temperature (°C DB)
- TC : Total capacity [kW]
- SHC : Sensible heat capacity [kW]
- PI : Power input [kW]

Notes

1. The ratings shown are net capacities which include a deduction for indoor fan motor heat.
2. The bold cells indicate the standard conditions.
Rated operating frequency [Hz]
3. The capacities are based on the following conditions:
Corresponding refrigerant piping length: 5 m
Level difference: 0m
4. The air flow rate and bypass factor are mentioned in the table.

3D113931B

4 Capacity tables

4 - 1 Cooling Capacity Tables

4

FTXF71D / RXF71D

Cooling 50 Hz 230 V

AFR	17,3
BF	0,27

Indoor temperature		Outdoor temperature [°C DB]																	
EWB	EDB	20			25			30			32			35			40		
°C	°C	TC	SHC	PI	TC	SHC	PI	TC	SHC	PI	TC	SHC	PI	TC	SHC	PI	TC	SHC	PI
14,0	20	7,28	5,14	2,14	6,95	4,97	2,33	6,61	4,79	2,48	6,48	4,73	2,61	6,28	4,62	2,74	5,95	4,46	2,94
16,0	22	7,60	5,05	2,15	7,27	4,88	2,34	6,93	4,73	2,50	6,80	4,66	2,64	6,61	4,56	2,74	6,28	4,41	2,94
18,0	25	7,93	5,25	2,17	7,60	5,10	2,37	7,27	4,94	2,50	7,14	4,88	2,64	6,93	4,79	2,77	6,60	4,65	2,96
19,0	27	8,09	5,50	2,17	7,76	5,34	2,37	7,43	5,20	2,50	7,30	5,14	2,64	7,10	5,06	2,77	6,77	4,92	2,97
22,0	30	8,58	5,28	2,20	8,25	5,15	2,38	7,92	5,02	2,52	7,79	4,98	2,66	7,58	4,89	2,79	7,27	4,78	2,99
24,0	32	8,91	5,13	2,19	8,58	5,01	2,40	8,25	4,89	2,54	8,12	4,85	2,68	7,92	4,78	2,79	7,58	4,66	2,99

Heating 50 Hz 230 V

AFR	17,9
-----	------

Indoor temperature		Outdoor temperature [°C WB]											
EDB		-15		-10		-5		0		6		10	
°C		TC	PI	TC	PI	TC	PI	TC	PI	TC	PI	TC	PI
15,0		3,90	1,79	4,70	1,87	5,48	1,94	6,26	2,02	8,48	2,56	9,22	2,63
20,0		3,67	1,83	4,45	1,90	5,24	1,97	6,03	2,09	8,20	2,60	8,94	2,67
22,0		3,57	1,85	4,36	1,92	5,14	2,00	5,92	2,10	8,08	2,63	8,83	2,70
24,0		3,47	1,86	4,26	1,94	5,05	2,01	5,83	2,13	7,98	2,64	8,72	2,71
25,0		3,42	1,87	4,21	1,96	5,00	2,03	5,79	2,14	7,92	2,66	8,66	2,73
27,0		3,33	1,88	4,11	1,96	4,90	2,03	5,69	2,16	7,80	2,67	8,54	2,74

Symbols

- AFR : Air flow rate [m³/min]
- BF : Bypass factor
- EWB : Entering wet-bulb temperature (°C WB)
- EDB : Entering dry-bulb temperature (°C DB)
- TC : Total capacity [kW]
- SHC : Sensible heat capacity [kW]
- PI : Power input [kW]

Notes

1. The ratings shown are net capacities which include a deduction for indoor fan motor heat.
2. The bold cells indicate the standard conditions.
Rated operating frequency [Hz]
3. The capacities are based on the following conditions:
Corresponding refrigerant piping length: 5 m
Level difference: 0m
4. The air flow rate and bypass factor are mentioned in the table.

3D115167A

5 Dimensional drawings

5 - 1 Dimensional Drawings

ARXF-D
RXF20-42D

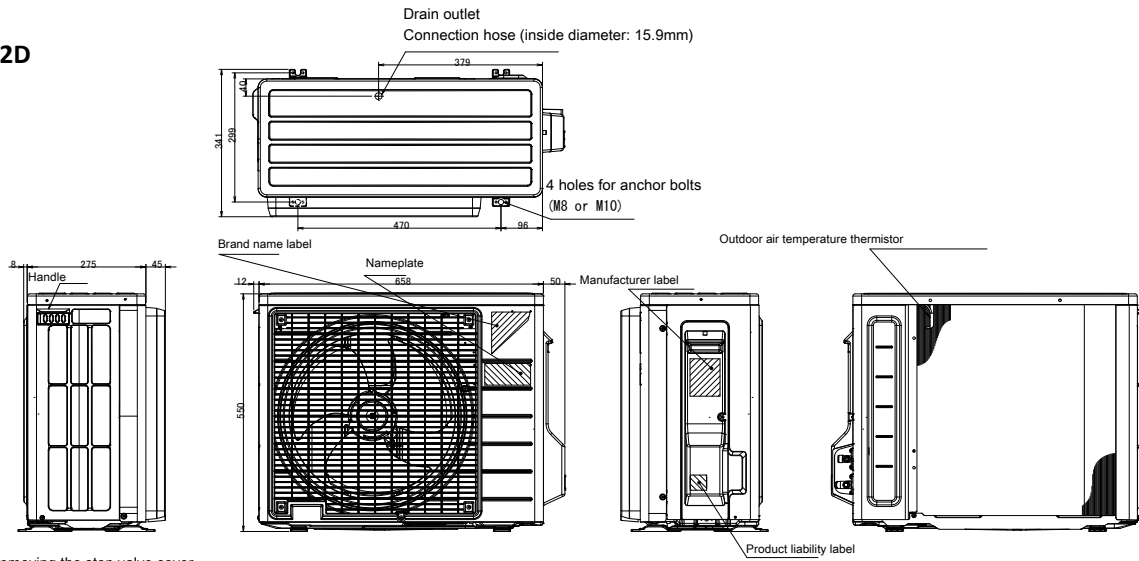

In case of removing the stop valve cover.

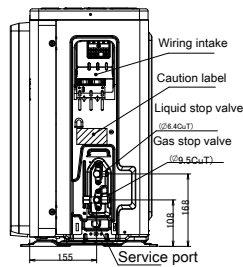

Minimum space for air passage
Wall height on air outlet side < 1200 mm

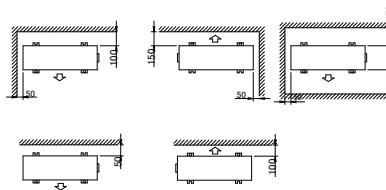

2D113526

RXF50-71D

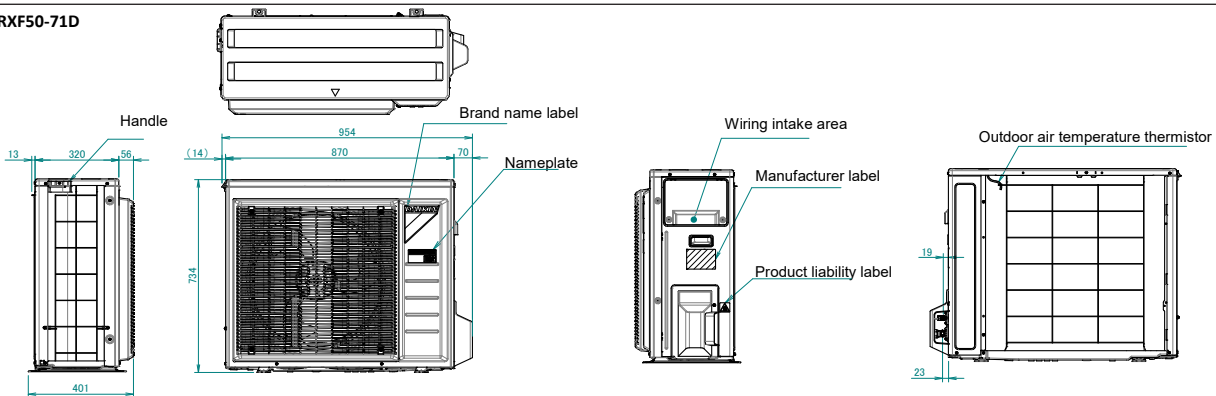

4 holes for anchor bolts
·M8· or ·M10·

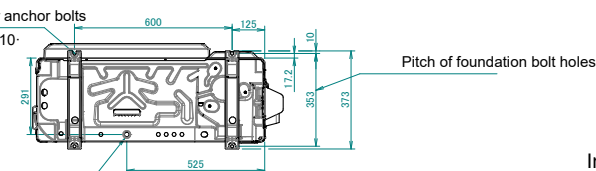

Drain outlet
Connection hose (inside diameter: ·15.9·mm)

Minimum space for air passage

Wall height on air outlet side < 1200 mm

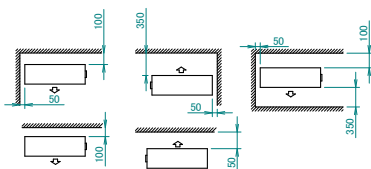

In case of removing the stop valve cover.

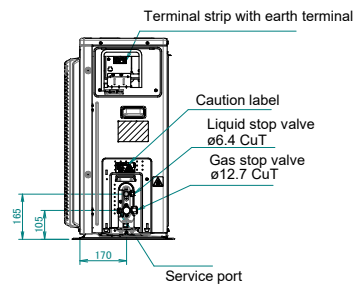

3D114108B

6 Centre of gravity

6 - 1 Centre of Gravity

6

ARXF20-35D
RXF20-35D

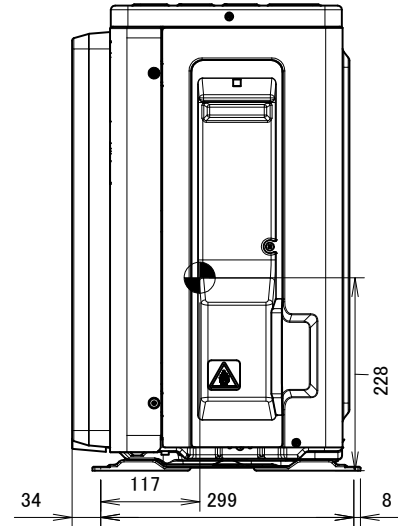
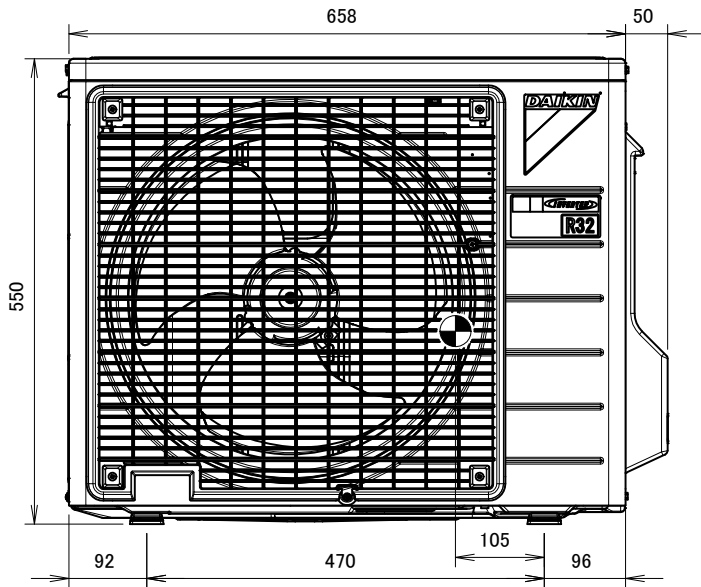

4D116239

ARXF42D
RXF42D

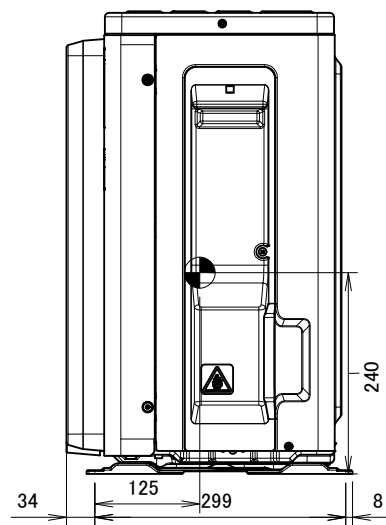
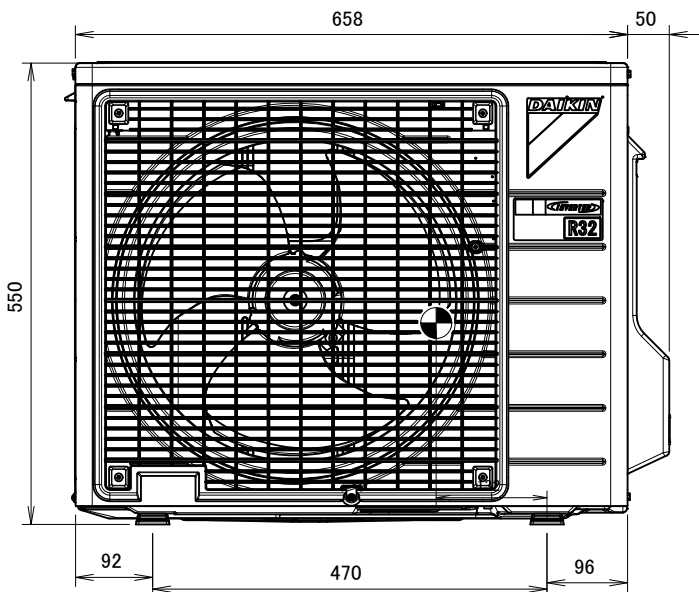

4D116242

6 Centre of gravity

6 - 1 Centre of Gravity

RXF50D

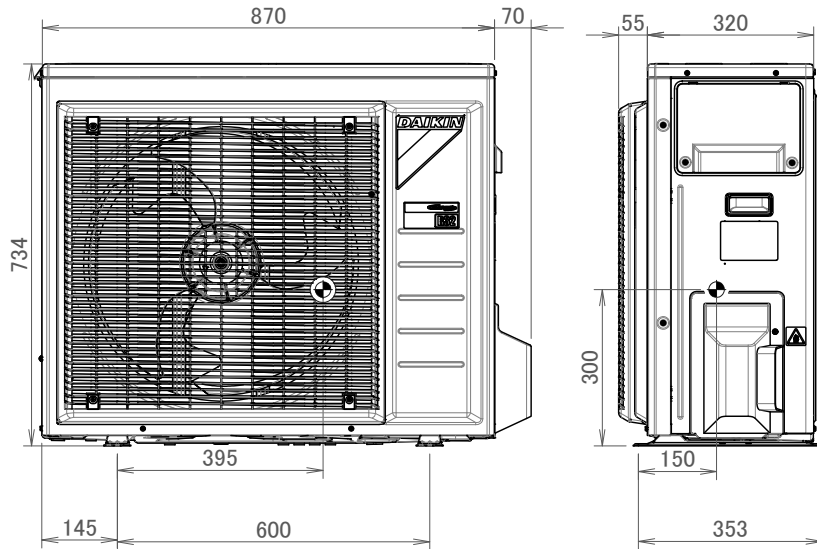

4D114820

RXF60-71D

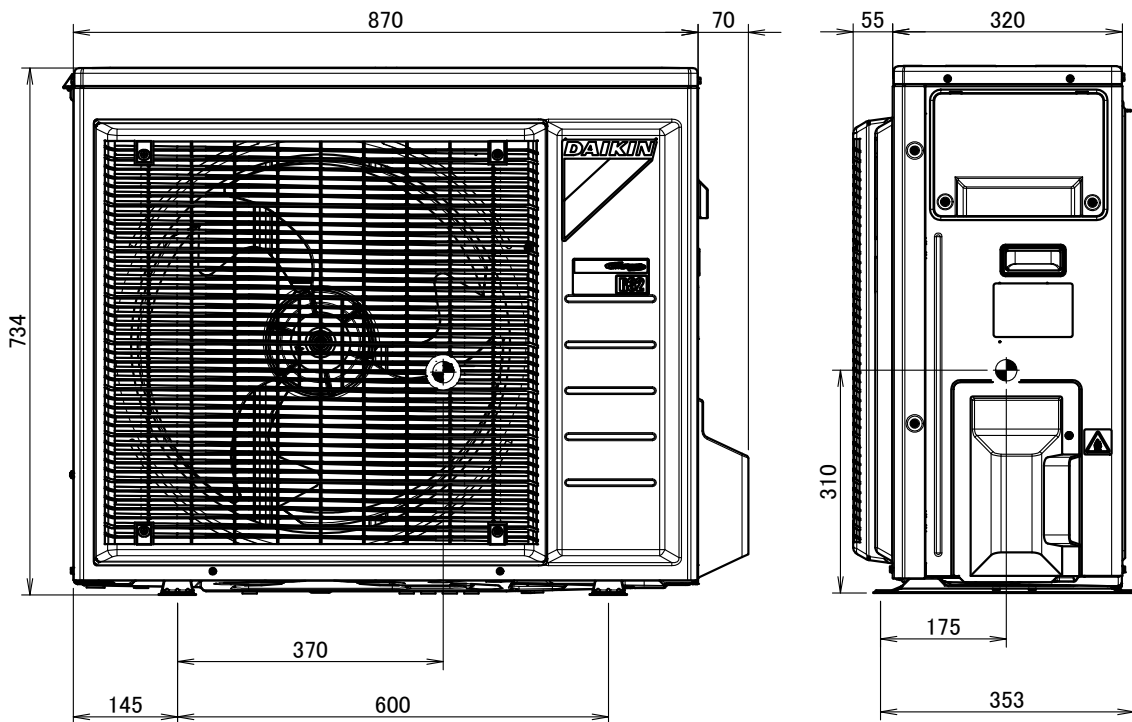

4D114824

7 Piping diagrams

7 - 1 Piping Diagrams

7

ARXF20-35D

RXF20-35D

Outdoor unit

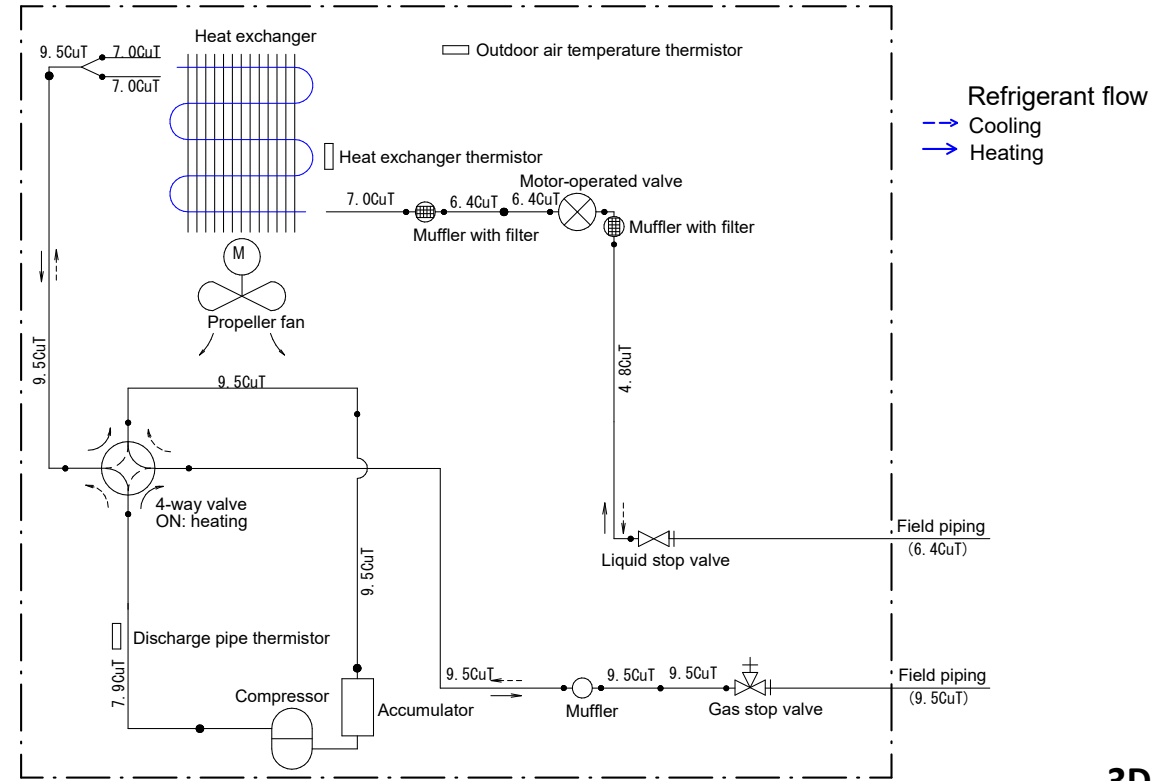

3D136644

ARXF42D

RXF42D

Outdoor unit

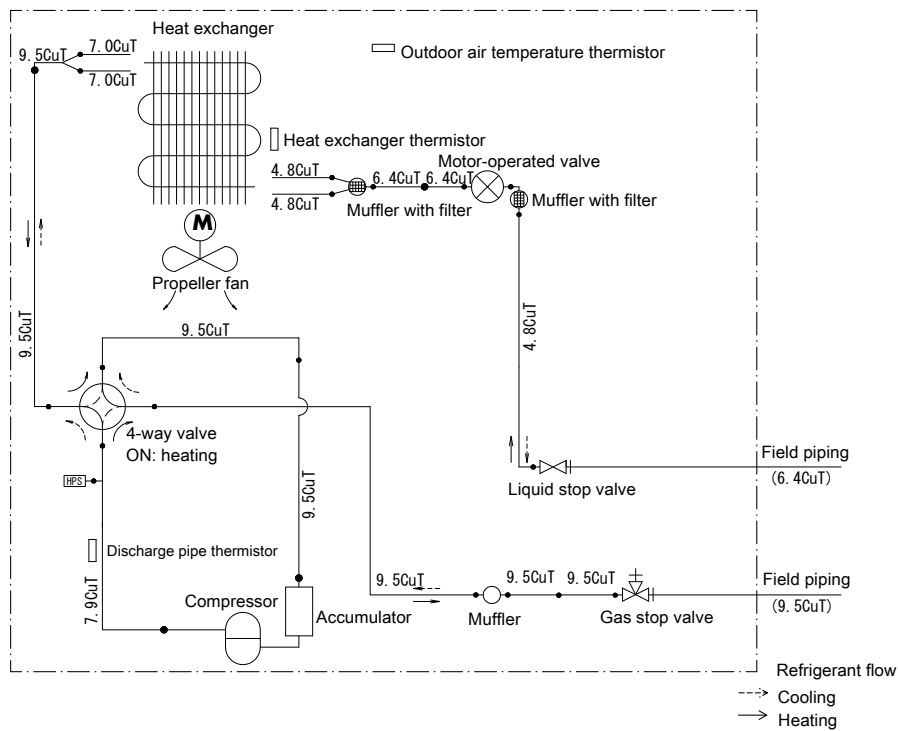

3D114612A

7 Piping diagrams

7 - 1 Piping Diagrams

RXF50D

Outdoor unit

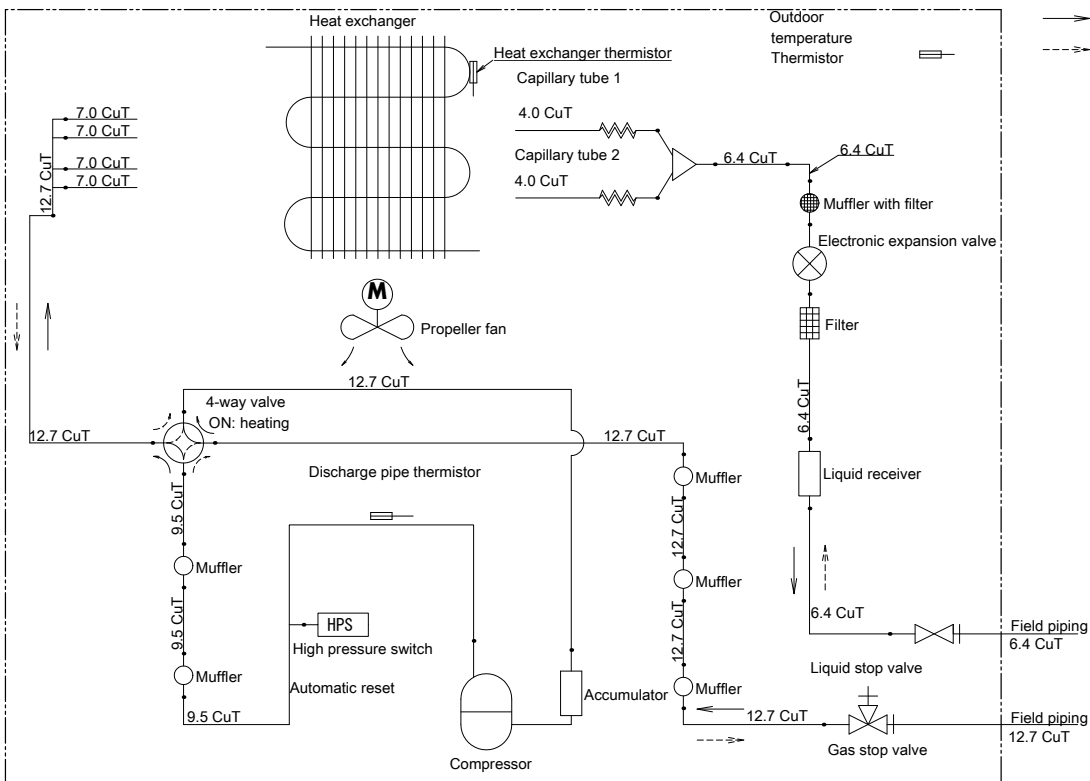

3D114451

RXF60-71D

Outdoor unit

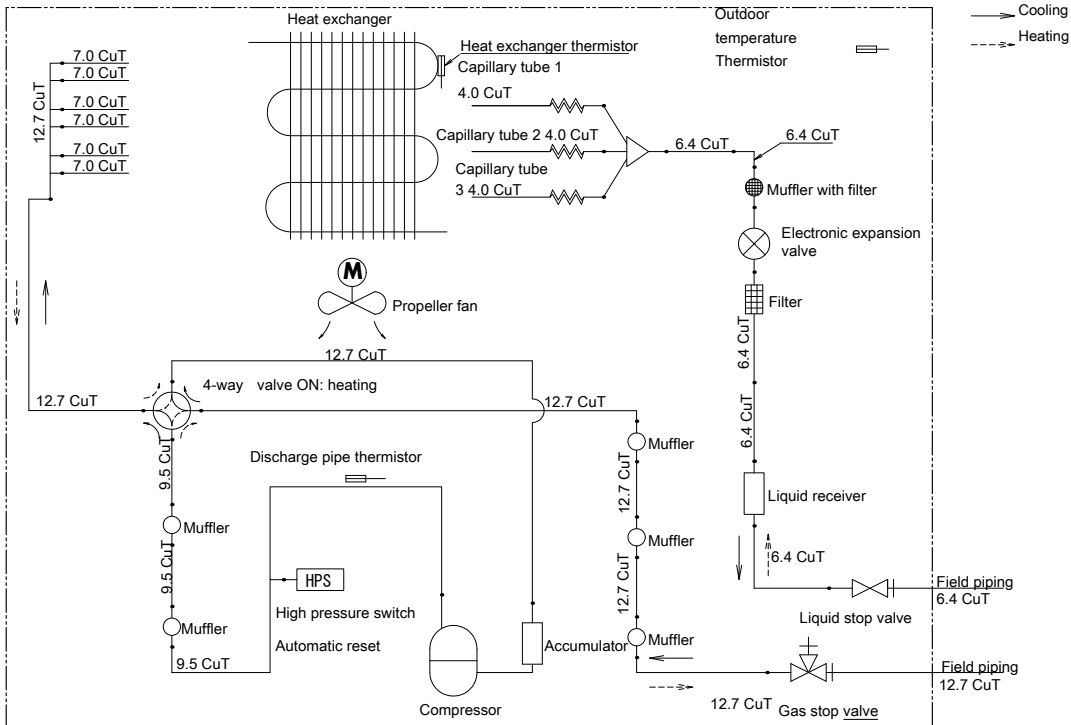

3D114450

8 Wiring diagrams

8 - 1 Wiring Diagrams - Single Phase

8

ARXF20-35D
RXF20-35D

Wiring diagram

Field wiring :

NOTE
Refer to the nameplate for the power requirements.

Wire colors

BLK	: Black
WHT	: White
BRN	: Brown
RED	: Red
GRN	: Green
YLW	: Yellow
ORG	: Orange
BLU	: Blue

C1, C2, C400, C405	Capacitor	SA1	Surge arrester
D401, D402	Diode	S, S10, S20, S30, S40, S71, S80, S90, E1, HR1, HR2, X1A	Connector
DB1	Diode bridge	V2, V3	Varistor
FU2, FU3	Fuse	X1M	Terminal strip
IPM1, IPM2	Intelligent power module	Y1S	Reversing solenoid valve coil
L1R	Reactor	PTC1	Thermistor PTC
M1C	Compressor motor	Y1E	Electronic expansion valve coil
M1F	Fan motor	Z1C, Z2C, Z3C	Ferrite core
K30R, K10R, MR4	Magnetic relay	ZF	Noise filter
A1P	Printed circuit board	⊕	Protective earth
PS	Switching power supply	⊥	Earth
Q1L	Overload protector		
R1T, R2T, R3T	Thermistor		

NOTES

- Size : length 140 x height 80
- Refer to purchasing specification AS303002, unless otherwise specified.
- This drawing was drawn on cad system.
- Refer to the "cad03919-3d134368-1-wiring-diagram-210406.ai" formatted file unless otherwise specified.

3D134368

8 Wiring diagrams

8 - 1 Wiring Diagrams - Single Phase

ARXF42D

RXF42D

Wiring diagram

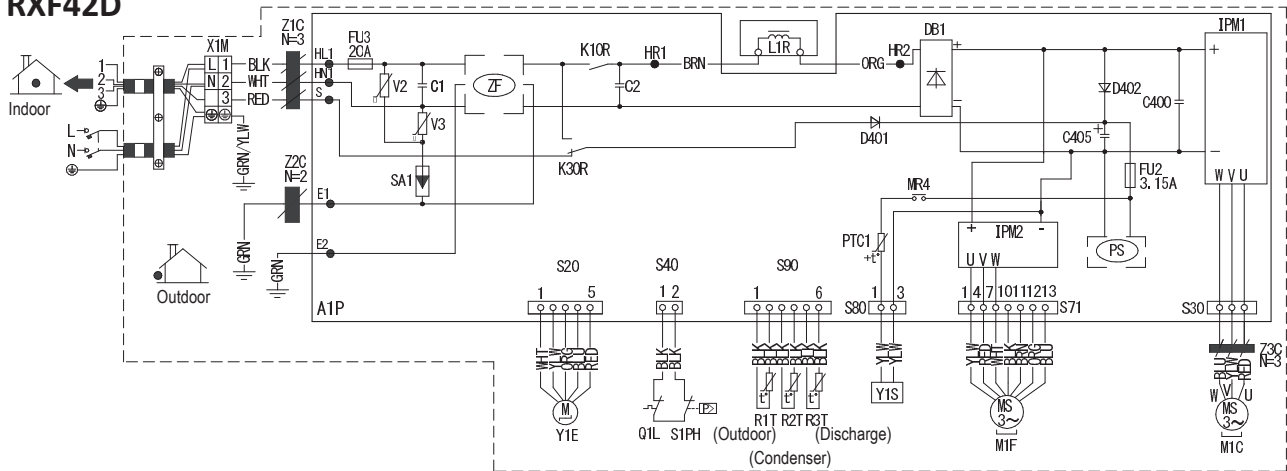

C1, C2, C400, C405	Capacitor
HL1, HN1, S, E1, E2, HR1, HR2	Connection
D401, D402	Diode
DB1	Diode bridge
FU2, FU3	Fuse
IPM1, IPM2	Intelligent power module
L1R	Reactor
M1C	Compressor motor
M1F	Fan motor
K30R, K10R, MR4	Magnetic relay
A1P	Printed circuit board
PS	Switching power supply
Q1L	Overload protector
R1T, R2T, R3T	Thermistor
S1PH	High pressure switch
SA1	Surge arrester
S20, S30, S40, S71, S80, S90	Connector
V2, V3	Varistor
X1M	Terminal strip
Y1S	Reversing solenoid valve coil
PTC1	Thermistor PTC
Y1E	Electronic expansion valve coil
Z1C, Z2C, Z3C	Ferrite core
ZF	Noise filter

BLK:	Black
WHT:	White
BRN:	Brown
RED:	Red
GRN:	Green
YLW:	Yellow
ORG:	Orange
BLU:	Blue

⊕ : Protective earth

⊚ : Earth

▬ : Field wiring

NOTES

1. Refer to the nameplate for the power requirements.

3D114611A

8 Wiring diagrams

8 - 1 Wiring Diagrams - Single Phase

8

RXF50-71D

Wiring diagram

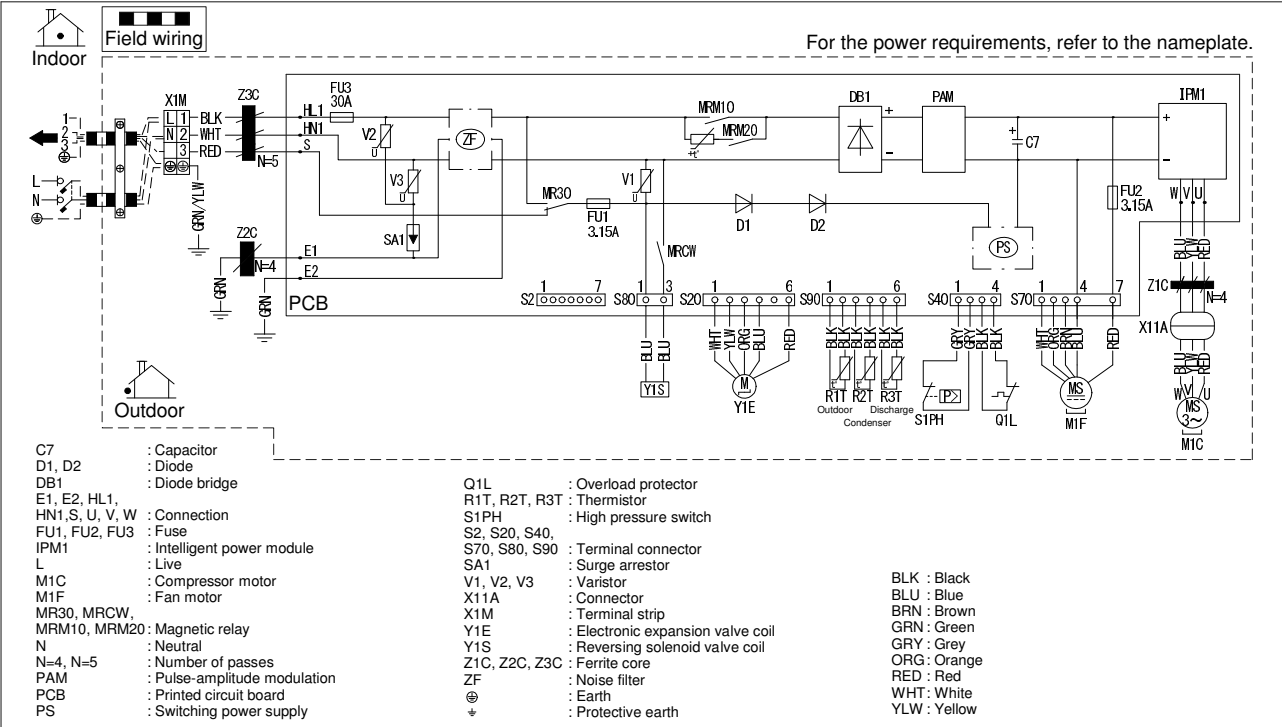

3D114452A

9 Sound data

9 - 1 Sound Pressure Spectrum

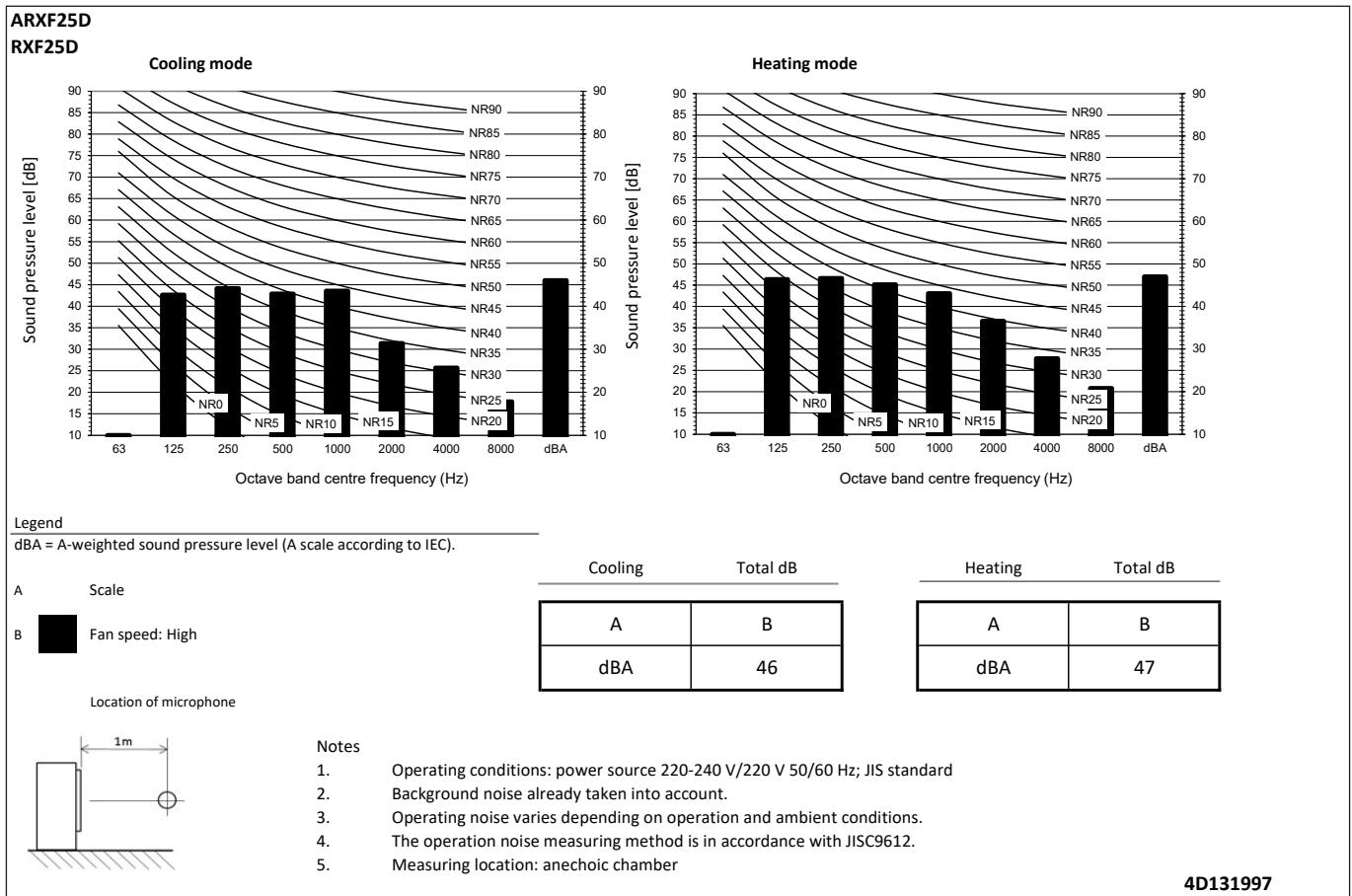
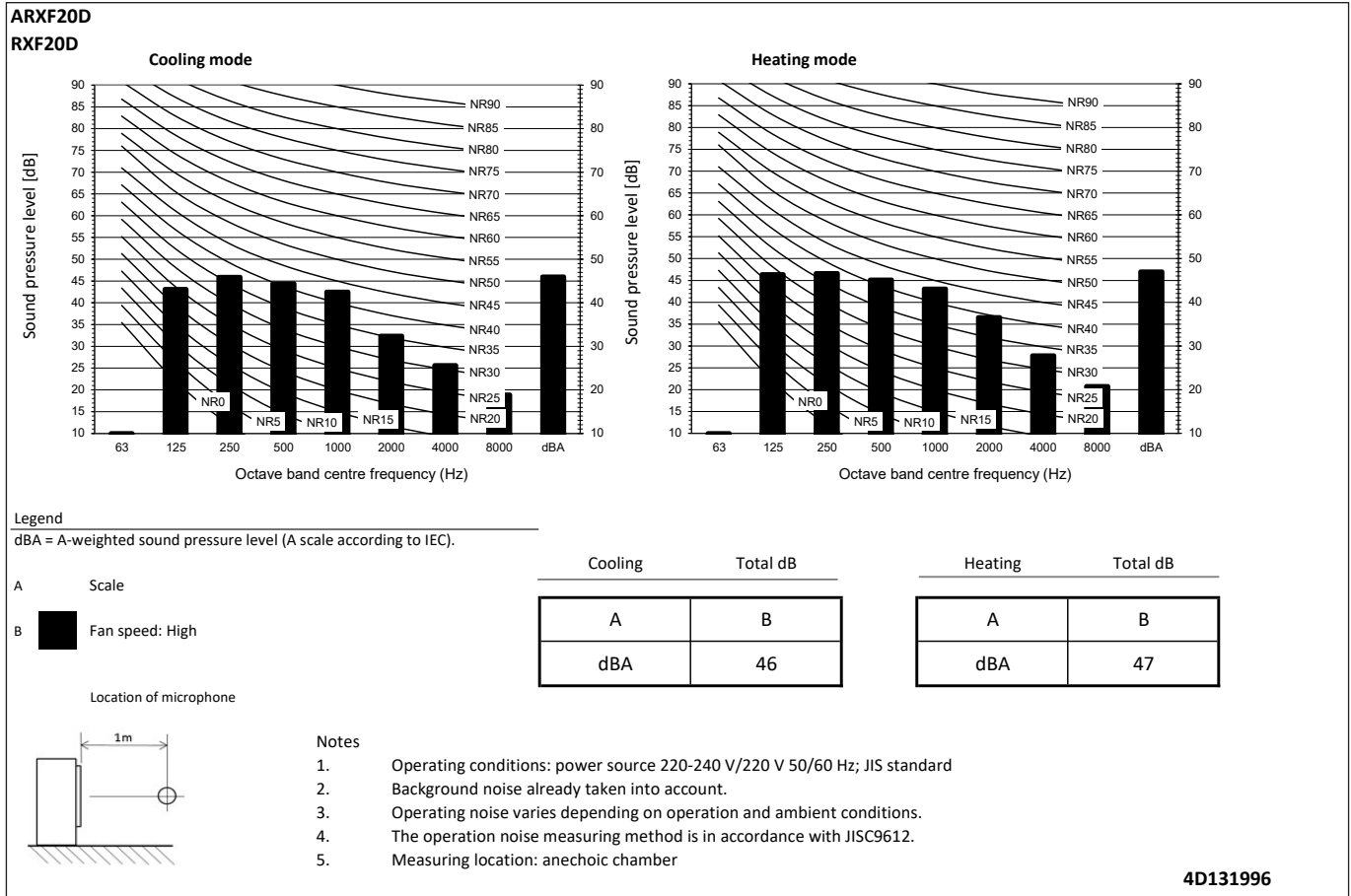

9 Sound data

9 - 1 Sound Pressure Spectrum

9

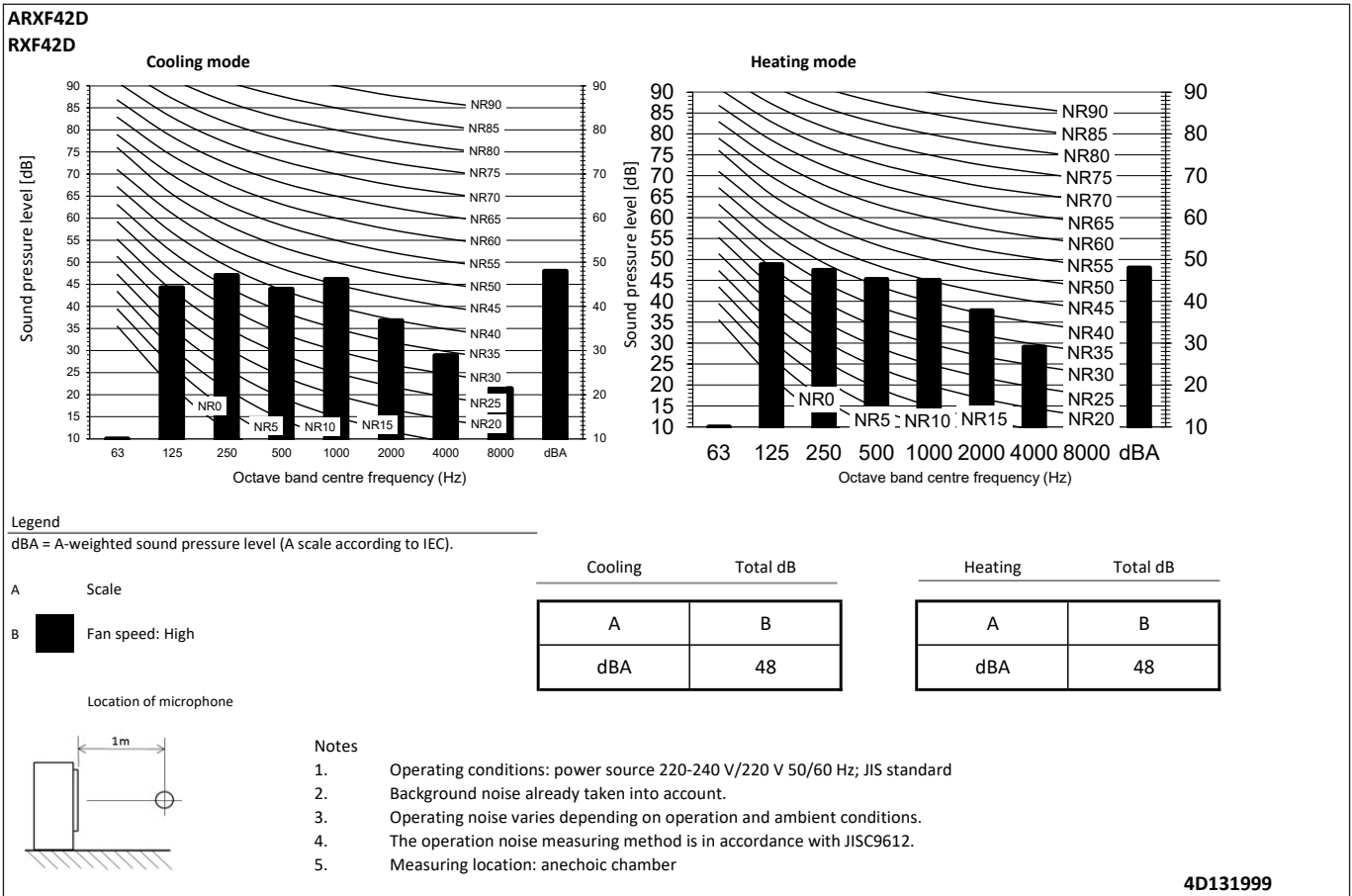
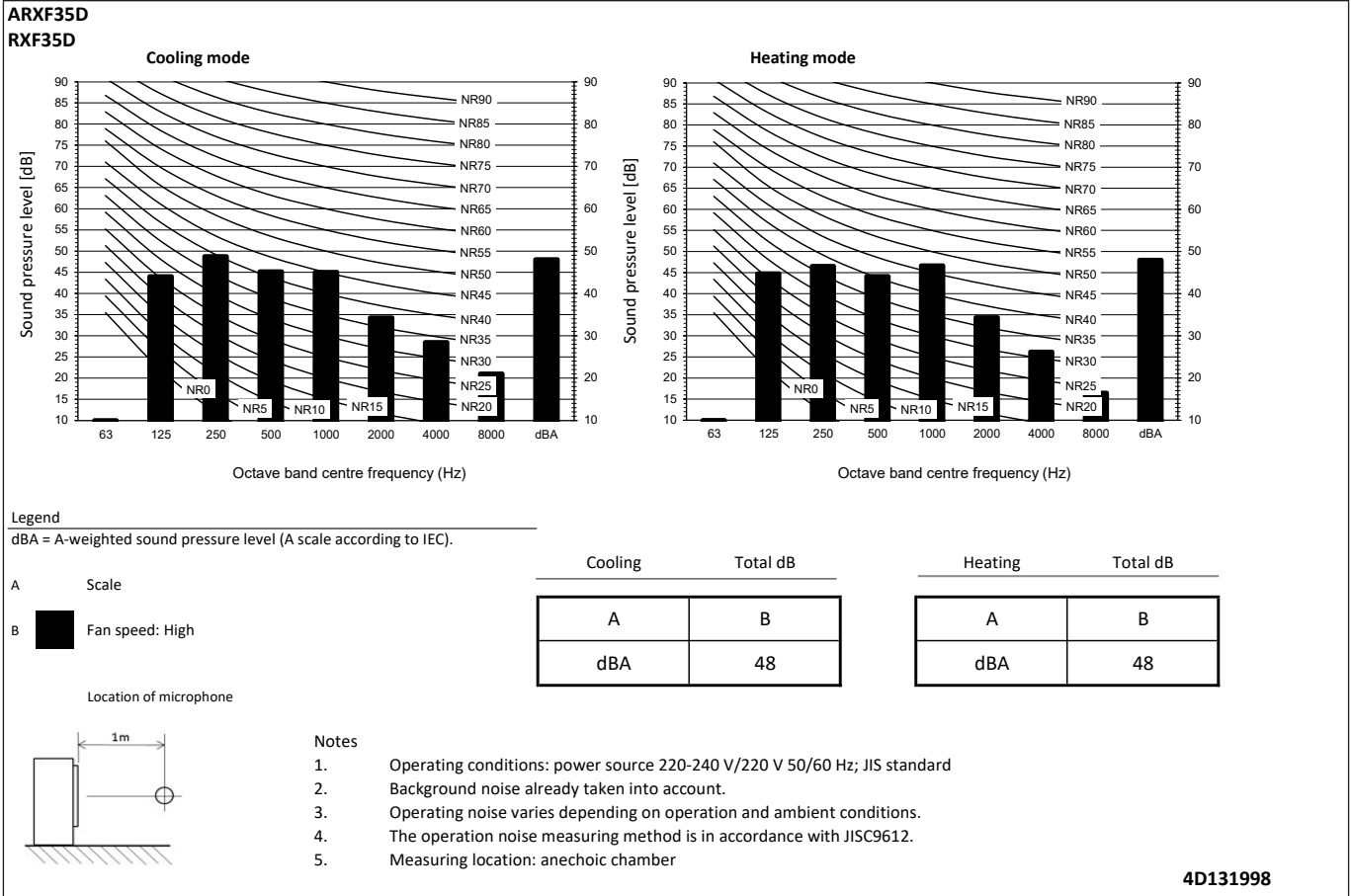

9 Sound data

9 - 1 Sound Pressure Spectrum

RXF50D

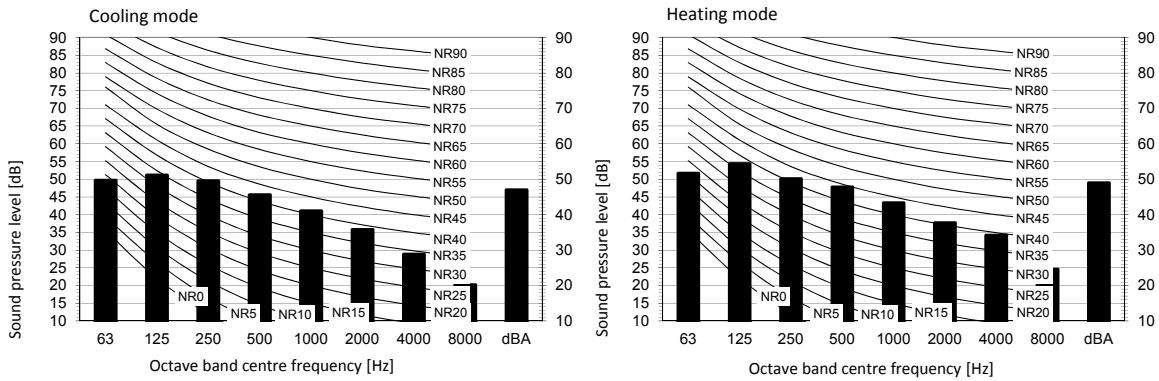

Legend

dBA = A-weighted sound pressure level (A scale according to IEC).

A Scale

B ■ Fan speed: High

Cooling		Total dB
A	B	
dBA		47

Heating		Total dB
A	B	
dBA		49

Location of microphone

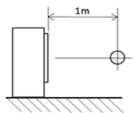

Notes

1. Operating conditions: power source 220-240 V/220 V 50/60 Hz; JIS standard
2. Background noise already taken into account.
3. Operating noise varies depending on operation and ambient conditions.
4. The operation noise measuring method is in accordance with JISC9612.
5. Measuring location: anechoic chamber

3D115241

RXF60D

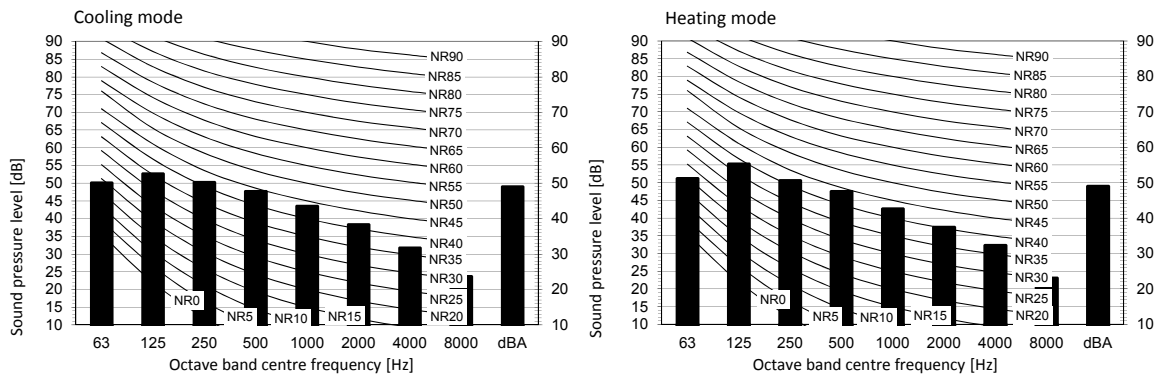

Legend

dBA = A-weighted sound pressure level (A scale according to IEC).

A Scale

B ■ Fan speed: High

Cooling		Total dB
A	B	
dBA		49

Heating		Total dB
A	B	
dBA		49

Location of microphone

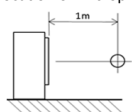

Notes

1. Operating conditions: power source 220-240 V/220 V 50/60 Hz; JIS standard
2. Background noise already taken into account.
3. Operating noise varies depending on operation and ambient conditions.
4. The operation noise measuring method is in accordance with JISC9612.
5. Measuring location: anechoic chamber

3D115242

9 Sound data

9 - 1 Sound Pressure Spectrum

9

RXF71D

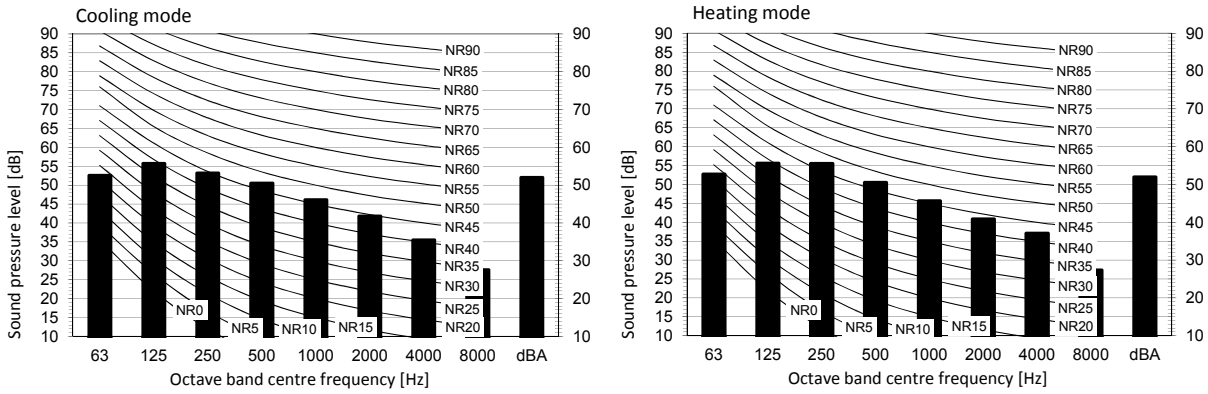

Legend

dBA = A-weighted sound pressure level (A scale according to IEC).

A Scale

B Fan speed: High

Cooling Total dB

A	B
dBA	52

Heating Total dB

A	B
dBA	52

Location of microphone

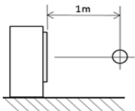

Notes

1. Operating conditions: power source 220-240 V/220 V 50/60 Hz; JIS standard
2. Background noise already taken into account.
3. Operating noise varies depending on operation and ambient conditions.
4. The operation noise measuring method is in accordance with JISC9612.
5. Measuring location: anechoic chamber

3D115243

10 Operation range

10 - 1 Operation Range

ARXF-D

RXF20-42D

Cooling

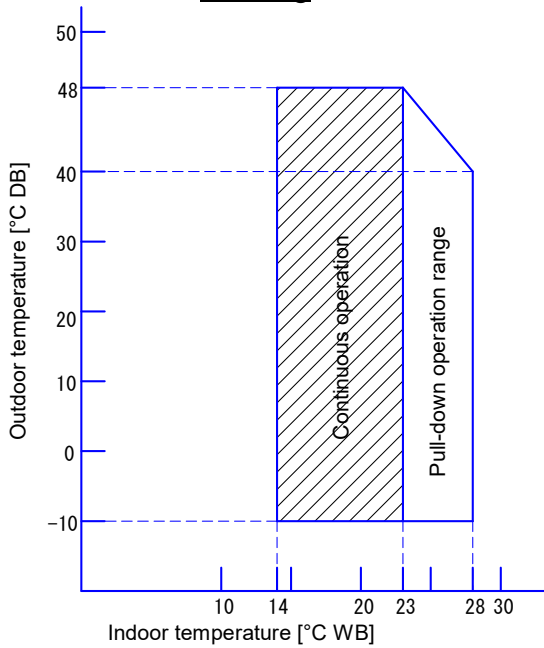

Heating

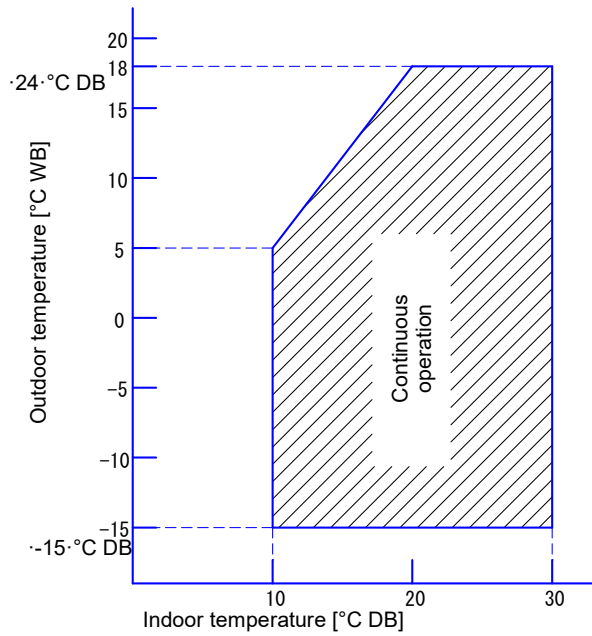

Notes

1.The graphs are based on the following conditions.

Corresponding refrigerant piping length: 5 m

Level difference: 0 m

Air flow rate High

2.Editable data for this drawing are available in the GDE (E-BOM) system.

3D669693

RXF50-71D

Cooling

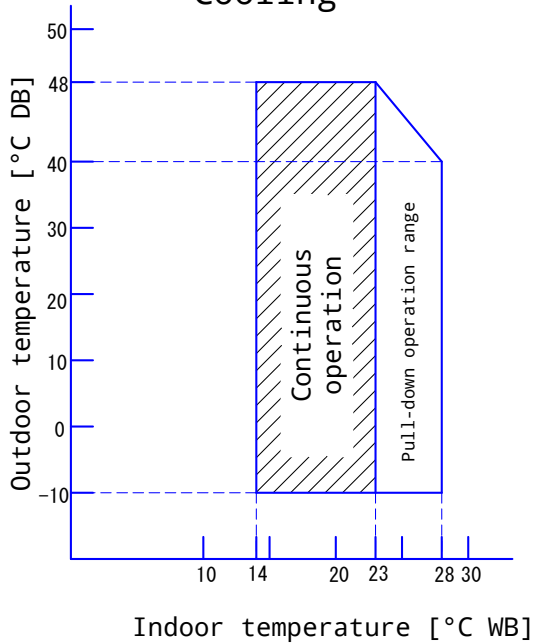

Heating

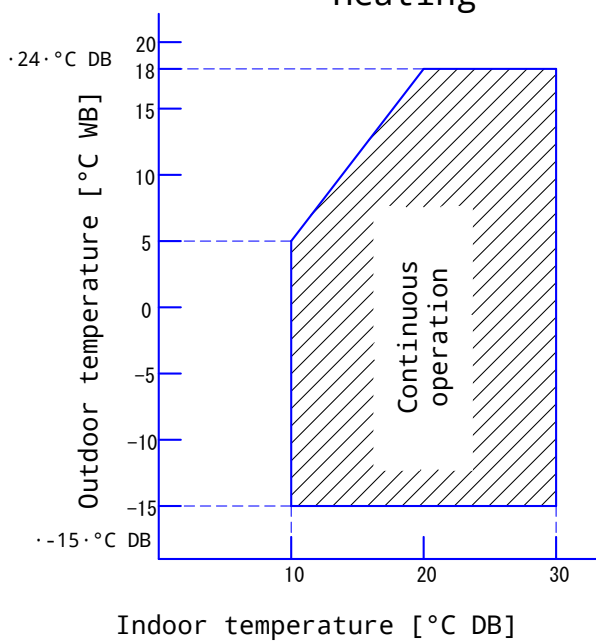

The graphs is based on the following conditions.

Corresponding refrigerant piping length: 5 m

Level difference: 0 m

Air flow rate High

3D136807

Daikin Europe N.V. Naamloze Vennootschap · Zandvoordestraat 300 · 8400 Oostende · Belgium · www.daikin.eu · BE 0412 120 336 · RPR Oostende (Responsible Editor)

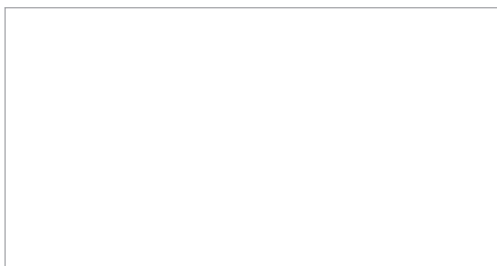

Daikin Europe N.V. participates in the ECP programmes for Fan Coil Units and Variable Refrigerant Flow systems. Daikin Applied Europe S.p.A. participates in the ECP programmes for Liquid Chilling Packages and Hydronic Heat Pumps. Check ongoing validity of certificate: www.eurovent-certification.com

EEEN22A

11/2022



The present leaflet is drawn up by way of information only and does not constitute an offer binding upon Daikin Europe N.V. Daikin Europe N.V. has compiled the content of this leaflet to the best of its knowledge. No express or implied warranty is given for the completeness, accuracy, reliability or fitness for particular purpose of its content and the products and services presented therein. Specifications are subject to change without prior notice. Daikin Europe N.V. explicitly rejects any liability for any direct or indirect damage, in the broadest sense, arising from or related to the use and/or interpretation of this leaflet. All content is copyrighted by Daikin Europe N.V.