

Ceiling mounted
corner cassette
Air Conditioning
Technical Data
FXKA-A



FXKA20AMVEB
FXKA25AMVEB
FXKA32AMVEB
FXKA40AMVEB
FXKA50AMVEB
FXKA63AMVEB

TABLE OF CONTENTS

FXKA-A

1	Features	4
	FXKA-A	4
2	Specifications	5
3	Safety device settings	7
4	Options	8
5	Capacity tables	9
	Cooling/Heating Capacity Tables	9
6	Dimensional drawings	10
7	Centre of gravity	11
8	Piping diagrams	13
9	Wiring diagrams	14
	Wiring Diagrams - Single Phase	14
10	Sound data	15
	Sound Power Spectrum	15
	Sound Pressure Spectrum	18
11	Air flow patterns	21
	Air flow pattern - Cooling and Heating	21

1 Features



















1 - 1 FXKA-A

1-way blow unit for corner installation

- 1 > Optimised design for R-32 refrigerant
- > Compact dimensions enable installation in narrow ceiling void (only 220mm high)
- > Modern style decoration panel in white

- > 5 different discharge angles between 0 and 60° can be programmed via the remote control
- > Optional fresh air intake
- > Standard drain pump with 630mm lift increases flexibility and installation speed



- | | | | | | | | | |
|---|---|---|--|---|--|---|---|--|
| 
Onecta app
(optional)
(optional) | 
Home leave
operation | 
Fan only | 
Draught
prevention | 
Auto cooling-
heating
changeover | 
Ceiling soiling
prevention | 
Individual flap
control | 
Vertical auto
swing | 
Fan speed
steps
(3 steps +
auto) |
| 
Dry
programme | 
Air filter
(pre filter) | 
Weekly timer
(optional) | 
Wired remote
control | 
Centralised
control
(optional) | 
Auto-restart | 
Self diagnosis | 
Multi tenant
(optional) | 
Drain pump
kit |

2 Specifications

2 - 1 Specifications

Technical specifications				FXKA20A	FXKA25A	FXKA32A	FXKA40A	FXKA50A	FXKA63A	
Cooling capacity	Sensible capacity	At high fan speed	kW	1.5	1.9	2.4	3	3.7	4.8	
		At medium fan speed	kW	1.3	1.7	2.1	2.6	3.1	3.9	
		At low fan speed	kW	1.1	1.5	1.8	2.2	2.7	3.2	
	Latent capacity	At high fan speed	kW	0.7	0.9	1.2	1.5	1.9	2.3	
		At medium fan speed	kW	0.6	0.8	1	1.3	1.6	1.9	
		At low fan speed	kW	0.6	0.7	0.9	1.2	1.3	1.5	
Total capacity	At high fan speed	kW	2.2	2.8	3.6	4.5	5.6	7.1		
	At medium fan speed	kW	1.9	2.5	3.1	3.9	4.7	5.8		
	At low fan speed	kW	1.7	2.2	2.7	3.4	4	4.7		
Heating capacity	Total capacity	At high fan speed	kW	2.5	3.2	4	5	6.3	8	
		At medium fan speed	kW	2.1	2.7	3.4	4.2	5.1	6.3	
		At low fan speed	kW	1.8	2.3	2.9	3.6	4.1	5	
Power input - 50Hz	Cooling	At high fan speed	kW	0.026		0.039	0.047	0.073	0.118	
		At medium fan speed	kW	0.02		0.031	0.036	0.047	0.073	
		At low fan speed	kW	0.014		0.026	0.029	0.036	0.047	
	Heating	At high fan speed	kW	0.034		0.039	0.047	0.073	0.118	
		At medium fan speed	kW	0.025		0.031	0.036	0.047	0.073	
		At low fan speed	kW	0.017		0.026	0.029	0.036	0.047	
Power input - 60Hz	Cooling	At high fan speed	kW	0.026		0.039	0.047	0.073	0.118	
	Heating	At high fan speed	kW	0.034		0.039	0.047	0.073	0.118	
Dimensions	Unit	Height	mm			200				
		Width	mm	840				1,240		
		Depth	mm			470				
	Packed unit	Height	mm			287				
		Width	mm	1,034				1,434		
		Depth	mm			607				
Weight	Unit	kg	18		19		24			
	Packed unit	kg	24		25		34			
Casing	Colour	Not painted (galvanised)								
	Material	Galvanised steel								
Required ceiling void >		mm	260							
Heat exchanger	Inside length	mm	627				997			
	Rows	Quantity	2				2/1			
	Fin pitch	mm	1.24				1.24 / 1.60			
	Passes	Quantity	5				7			
	Face area	m ²	0.158				0.251			
Heat exchanger	Stages	Quantity	14				14/8			
	Empty tubeplate hole	Quantity	0							
	Tube type	ø6.35 Hi-XU								
	Fin	Type	Multi slit fin							
Fan	Type	Sirocco fan								
		Quantity	2				4			
	Air flow rate - 50Hz	Cooling	At high fan speed	m ³ /min	7.5		9.4	14.4	17.6	21.5
			At medium fan speed	m ³ /min	6.3		8.5	12.6	14.4	17.6
			At low fan speed	m ³ /min	5		7.6	11.1	12.6	14.4
		Heating	At high fan speed	m ³ /min	8.6		9.4	14.4	17.6	21.5
			At medium fan speed	m ³ /min	7.3		8.5	12.6	14.4	17.6
			At low fan speed	m ³ /min	5.8		7.6	11.1	12.6	14.4
	Air flow rate - 60Hz	Cooling	At high fan speed	cfm	265		332	509	622	759
			At medium fan speed	cfm	222		300	445	509	622
Heating		At high fan speed	cfm	304		332	509	622	759	
		At medium fan speed	cfm	258		300	445	509	622	
Sound power level	Cooling	At high fan speed	dBA	46		50.5	52.5	57	61.5	
		At medium fan speed	dBA	43.5		48.5	50	52.5	57	
		At low fan speed	dBA	41		46.5	48	50	52.5	
	Heating	At high fan speed	dBA	50		52.5	53	58	63.5	
		At medium fan speed	dBA	46		49.5	50.5	53	58	
		At low fan speed	dBA	41.5		47	48	50.5	53	
	Sound pressure level	Cooling	At high fan speed	dBA	32		37	38.5	42	48.5
			At medium fan speed	dBA	27.5		34	34.5	38	43.5
			At low fan speed	dBA	22.5		31.5		34.5	38.5
		Heating	At high fan speed	dBA	36		39	39.5	44	49
At medium fan speed			dBA	31		35.5	36	39.5	44	
At low fan speed			dBA	25.5		32.5		36	39.5	
Fan motor	Quantity	1								
	Output	Max	W		87		117			

2 Specifications

2 - 1 Specifications

2

Technical specifications			FXKA20A	FXKA25A	FXKA32A	FXKA40A	FXKA50A	FXKA63A	
Refrigerant	Type		R-32						
	GWP		675						
	Control		Electronic expansion valve						
Piping connections	Liquid	Type	Flare connection						
		OD	mm	6.4					
Piping connections	Gas	Type	Flare connection						
		OD	mm	9.5			12.7		
	Drain		I.D. 20/O.D. 26						
	Heat insulation		Both liquid and gas pipes						
Decoration panel	Model		BYK32GJW1			BYK63GJW1			
	Colour		Fresh White						
	Dimensions	Height	mm	80					
		Width	mm	950			1,350		
		Depth	mm	550					
Weight	kg	8			10				
Air filter	Type		Removable / washable						
Safety devices	Item	01	PC board fuse						
		02	Fan motor overcurrent protection						
Control systems	Wired remote control		BRC1H52W/S/K / BRC1H82W/S/K						

Standard accessories: General safety precautions;Quantity: 1;

Standard accessories: Sealing material (drain hose);Quantity: 1;

Standard accessories: Clamp for drain hose;Quantity: 1;

Standard accessories: Drain hose;Quantity: 1;

Standard accessories: Installation and operation manual;Quantity: 1;

Standard accessories: Paper pattern for installation;Quantity: 1;

Electrical specifications			FXKA20A	FXKA25A	FXKA32A	FXKA40A	FXKA50A	FXKA63A
Power supply	Name		VE					
	Phase		1~					
	Frequency		50/60					
	Voltage		220-240/220					
Current - 50Hz	Minimum circuit amps (MCA)		0.4			0.6	0.9	1.4
	Maximum fuse amps (MFA)		6					
	Full load amps (FLA) Total		0.3		0.35	0.5	0.8	1.25
Current - 60Hz	Minimum circuit amps (MCA)		0.4			0.6	0.9	1.4
	Maximum fuse amps (MFA)		6					
	Full load amps (FLA) Total		0.3		0.35	0.5	0.8	1.25

Nominal cooling capacities are based on: indoor temperature: 27°CDB, 19°CWB, outdoor temperature: 35°CDB, equivalent refrigerant piping: 5m, level difference: 0m. |

Nominal heating capacities are based on: indoor temperature: 20°CDB, outdoor temperature: 7°CDB, 6°CWB, equivalent refrigerant piping: 5m, level difference: 0m. |

The sound power level is an absolute value indicating the power which a sound source generates. |

Instead of a fuse, use a circuit breaker |

Select wire size based on the value of MCA

3 Safety device settings

3 - 1 Safety Device Settings

FXKA-A
FXKQ-A

3

Safety devices		FXKA20-63AMVEB FXKQ20-63AMVEB
PCB fuse		250V, 3.15A
Fan motor overcurrent protection	Nominal	1.65 A

4D150975

4 Options

4 - 1 Options

4

FXKA-A

Option kit	Product name	FXKA20AMVEB FXKA25AMVEB FXKA32AMVEB	FXKA40AMVEB FXKA50AMVEB FXKA63AMVEB
Decoration panel	BYK32GJW1 (1)	✓	✗
	BYK63GJW1 (1)	✗	✓
Wired remote control	BRC1H52/82W/S/K (1)	✓	✓
Wiring adaptor for electrical appendices	KRP4A53 (6)	✓	✓
Wiring adaptor for electrical appendices	KRP2A526 (6)	✓	✓
Adapter with ·4· output signals	EKRP1C14 (6)	✓	✓
Remote sensor	KRCS01-6B	✓	✓
Central remote control	DCS302CA61 (3)	✓	✓
Unified ON/OFF controller	DCS301BA61 (4)	✓	✓
Electrical box with earth terminal (·2· blocks)	KJB212AA	✓	✓
Electrical box with earth terminal (·3· blocks)	KJB311AA	✓	✓
Electrical box with earth terminal	KJB411A	✓	✓
PCB for multi-tenant indoor units	DTA114A61-9 (6)	✓	✓
External adaptor for outdoor unit (installation on indoor unit)	DTA104A61 (6)	✓	✓
iTouch Controller	DCS601C51 (5)	✓	✓
Digital input adaptor	BRP7A51 (6) (2)	✓	✓
Intelligent Touch Manager	DCM601B51	✓	✓
Optional output PCB	ERP01A51 (6)	✓	✓
WLAN adaptor for smartphones	BRP069C51 (2)	✓	✓
Installation box for adaptor PCB	KRP4B93	✓	✓
Wire harness for external wireless temperature sensor	EKEWTSC-1 (7)	✓	✓

Notes

- ① Mandatory option
- ② Only possible in combination with remote control ·BRC1H*·.
- ③ Requires installation box ·KJB212AA·.
- ④ Requires installation box ·KJB311AA·.
- ⑤ Requires installation box ·KJB411A·.
- ⑥ Requires installation box ·KRP4B93·.
- ⑦ ·EKEWTSC-1· is a wire harness for the connection of option ·K.RSS·.
·K.RSS· is not an official option. Sales for this option are an SBU responsibility.

3D150681

5 Capacity tables

5 - 1 Cooling/Heating Capacity Tables

FXKA-A Cooling

Unit size	Fan speed	Indoor air temperature													
		14,0 [°C WB]		16,0 [°C WB]		18,0 [°C WB]		19,0 [°C WB]		20,0 [°C WB]		22,0 [°C WB]		24,0 [°C WB]	
		TC	SHC	TC	SHC	TC	SHC	TC	SHC	TC	SHC	TC	SHC	TC	SHC
20	H	1,3	1,0	1,6	1,2	2,0	1,4	2,2	1,5	2,4	1,5	2,8	1,6	3,3	1,8
	M	Correction factor -0.86 × H-													
	L	Correction factor -0.77 × H-													
25	H	1,7	1,3	2,1	1,5	2,6	1,8	2,8	1,9	3,1	1,9	3,6	2,1	4,2	2,2
	M	Correction factor -0.89 × H-													
	L	Correction factor -0.79 × H-													
32	H	2,1	1,7	2,7	2,0	3,3	2,3	3,6	2,4	3,9	2,5	4,7	2,7	5,4	2,9
	M	Correction factor -0.86 × H-													
	L	Correction factor -0.75 × H-													
40	H	2,7	2,1	3,4	2,5	4,1	2,9	4,5	3,0	4,9	3,1	5,8	3,3	6,7	3,5
	M	Correction factor -0.87 × H-													
	L	Correction factor -0.76 × H-													
50	H	3,4	2,6	4,2	3,1	5,1	3,6	5,6	3,7	6,1	3,9	7,1	4,2	8,2	4,4
	M	Correction factor -0.84 × H-													
	L	Correction factor -0.71 × H-													
63	H	4,3	3,4	5,4	4,1	6,5	4,7	7,1	4,8	7,7	5,0	9,0	5,3	10,3	5,6
	M	Correction factor -0.82 × H-													
	L	Correction factor -0.66 × H-													

Notes
 1) TC: Total capacity [kW]
 SHC: Sensible heat capacity [kW]
 H: High
 M: Medium
 L: Low
 2) Outdoor temperature :35-°C DB

Heating

Unit size	Fan speed	Indoor air temperature					
		16,0 [°C DB]	18,0 [°C DB]	20,0 [°C DB]	21,0 [°C DB]	22,0 [°C DB]	24,0 [°C DB]
20	H	TC	TC	TC	TC	TC	TC
	M	2,9	2,7	2,5	2,4	2,3	2,1
	L	Correction factor -0.84 × H-					
25	H	3,7	3,4	3,2	3,1	3,0	2,7
	M	Correction factor -0.84 × H-					
	L	Correction factor -0.72 × H-					
32	H	4,6	4,3	4,0	3,8	3,7	3,4
	M	Correction factor -0.85 × H-					
	L	Correction factor -0.73 × H-					
40	H	5,8	5,4	5,0	4,8	4,6	4,2
	M	Correction factor -0.84 × H-					
	L	Correction factor -0.72 × H-					
50	H	7,3	6,8	6,3	6,1	5,8	5,4
	M	Correction factor -0.81 × H-					
	L	Correction factor -0.65 × H-					
63	H	9,2	8,6	8,0	7,7	7,4	6,8
	M	Correction factor -0.79 × H-					
	L	Correction factor -0.63 × H-					

Notes
 1) TC: Total capacity [kW]
 H: High
 M: Medium
 L: Low
 2) Outdoor temperature :7-°C DB / -6-°C WB

4D151058

6 Dimensional drawings

6 - 1 Dimensional Drawings

6

FXKA20-32A
FXKQ20-32A

- Notes
1. Location of nameplate
The unit nameplate is located on the control box cover.
The decoration panel nameplate is located on the inner frame inside the suction grille.
 2. Though the installation is acceptable up to maximum 910x510-mm square ceiling opening, keep the clearance of 35-mm or less between the indoor unit and the ceiling opening, so that the panel overlap allowance can be ensured.
 3. When installing optional accessories, refer to their respective documentation.
 4. If any of the following conditions are met, additional insulation (glass wool or polyethylene foam, thickness ≥ 10-mm) is required:
Fresh air is inducted into the ceiling.
The unit operates continuously.

Model	øA	øB
FXKQ20AMVEB	6.4	12.7
FXKQ25AMVEB	6.4	12.7
FXKQ30AMVEB	6.4	12.7
FXKA20AMVEB	6.4	9.5
FXKA25AMVEB	6.4	9.5
FXKA30AMVEB	6.4	9.5

Item	Part name	Item	Part name
①	Liquid pipe connection -øA-	⑥	Air discharge side
②	Gas pipe connection -øB-	⑦	Air suction side
③	Drain outlet Inside diameter: 20-mm Outside diameter: 25-mm	⑧	Drain hose (accessory)
④	Power supply wiring intake	⑨	Inside diameter: 25-mm
⑤	Wiring connection Remote control wiring intake	⑩	Metal hanger

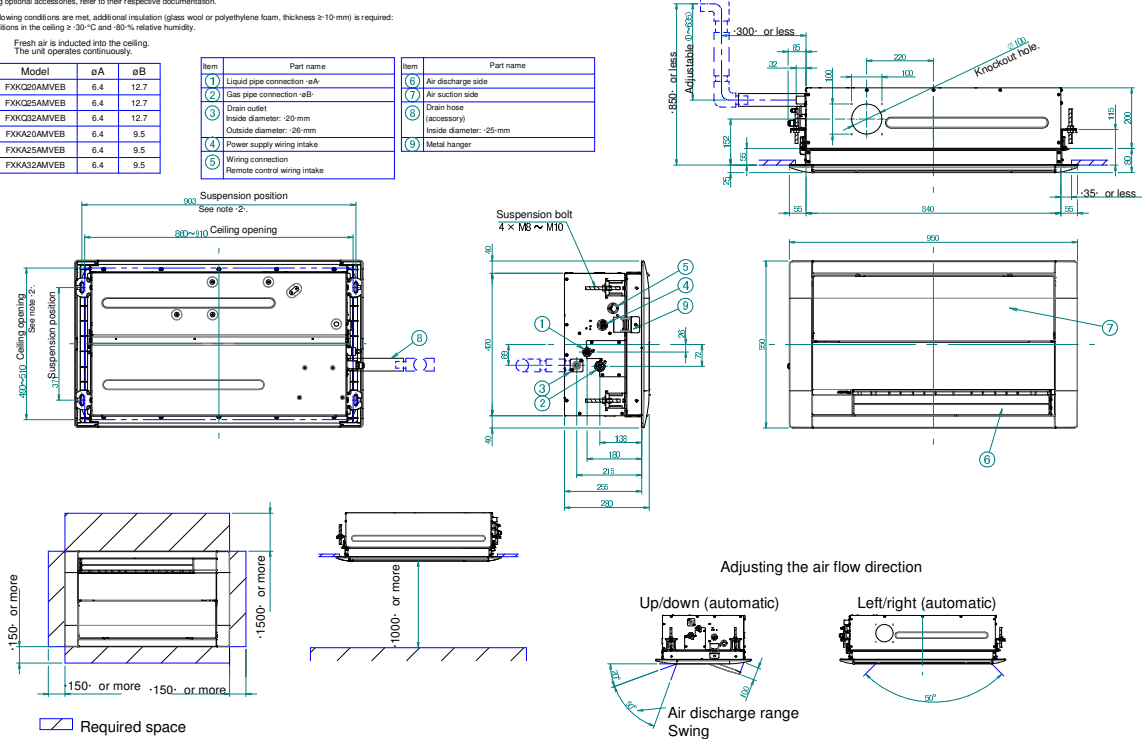

2D146914A

FXKA40-63A
FXKQ40-63A

- Notes
1. Location of nameplate
The unit nameplate is located on the control box cover.
The decoration panel nameplate is located on the inner frame inside the suction grille.
 2. Though the installation is acceptable up to maximum 1310x510-mm square ceiling opening, keep the clearance of 35-mm or less between the indoor unit and the ceiling opening, so that the panel overlap allowance can be ensured.
 3. When installing optional accessories, refer to their respective documentation.
 4. If any of the following conditions are met, additional insulation (glass wool or polyethylene foam, thickness ≥ 10-mm) is required:
Fresh air is inducted into the ceiling.
The unit operates continuously.

Model	øA	øB
FXKQ40AMVEB	6.4	12.7
FXKQ50AMVEB	6.4	12.7
FXKQ63AMVEB	9.5	15.9
FXKA40AMVEB	6.4	12.7
FXKA50AMVEB	6.4	12.7
FXKA63AMVEB	6.4	12.7

Item	Part name	Item	Part name
①	Liquid pipe connection -øA-	⑥	Air discharge side
②	Gas pipe connection -øB-	⑦	Air suction side
③	Drain outlet Inside diameter: 20-mm Outside diameter: 25-mm	⑧	Drain hose (accessory)
④	Power supply wiring intake	⑨	Inside diameter: 25-mm
⑤	Wiring connection Remote control wiring intake	⑩	Metal hanger

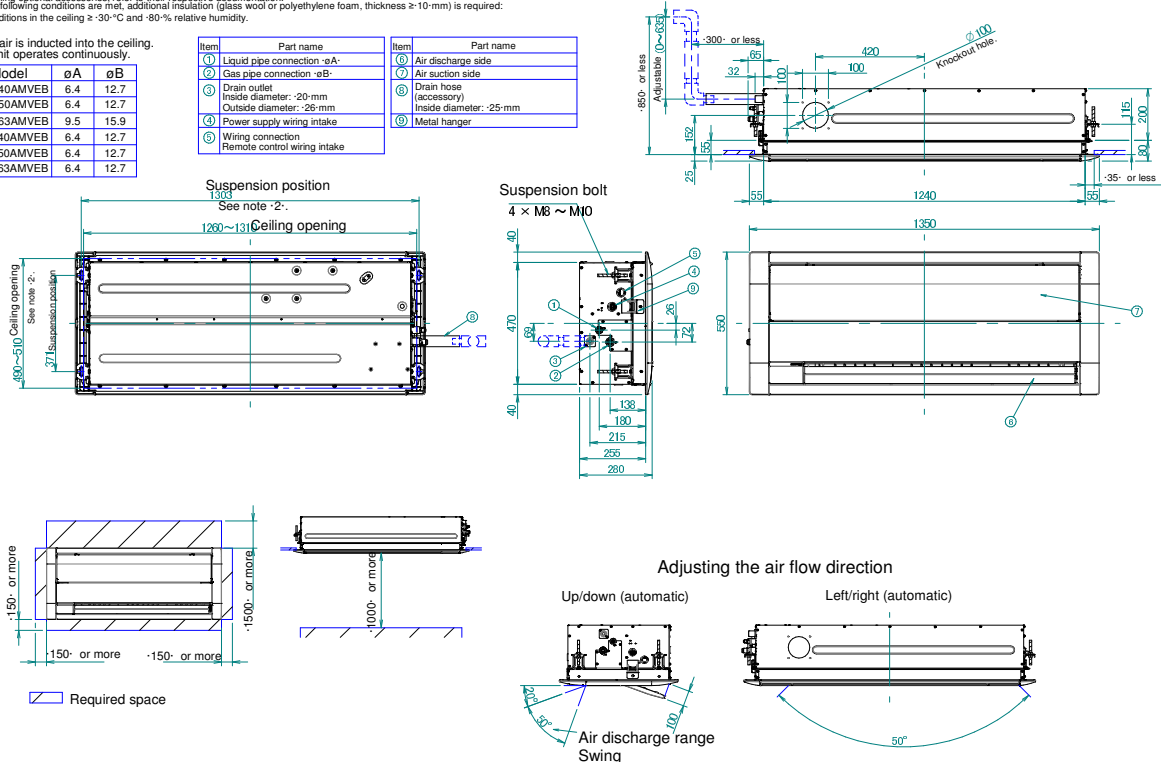

2D148806A

7 Centre of gravity

7 - 1 Centre of Gravity

**FXKA20-25A
FXKQ20-25A**

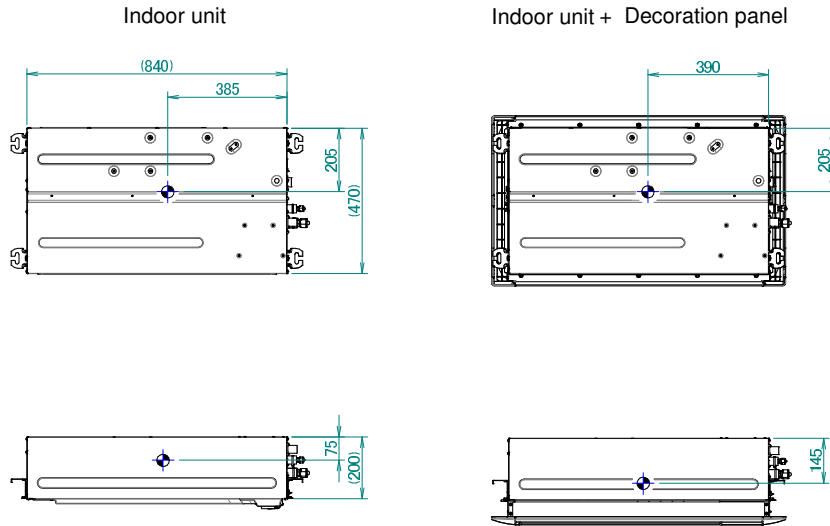

3D148595

**FXKA32A
FXKQ32A**

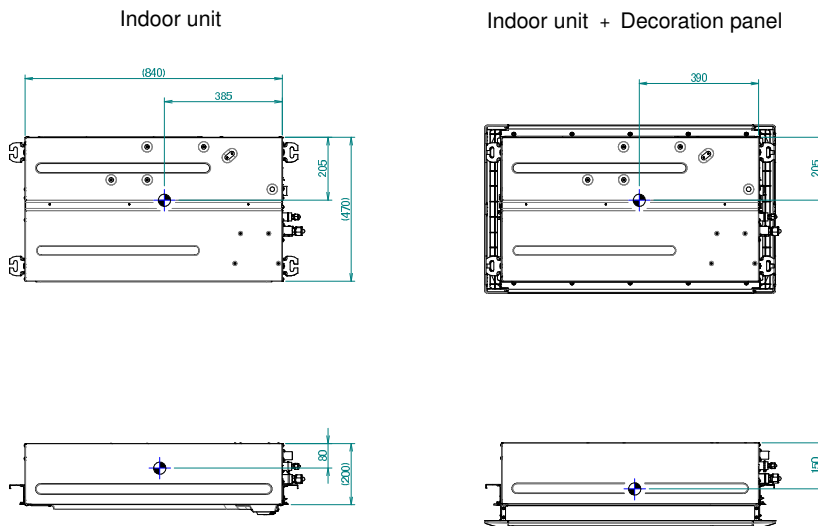

3D148865

7 Centre of gravity

7 - 1 Centre of Gravity

7

FXKA40-63A
FXKQ40-63A

Indoor unit

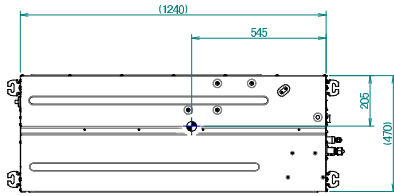

Indoor unit + Decoration panel

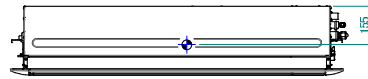
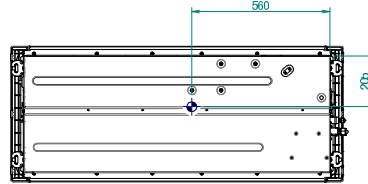

3D148866

8 Piping diagrams

8 - 1 Piping Diagrams

FXKA-A

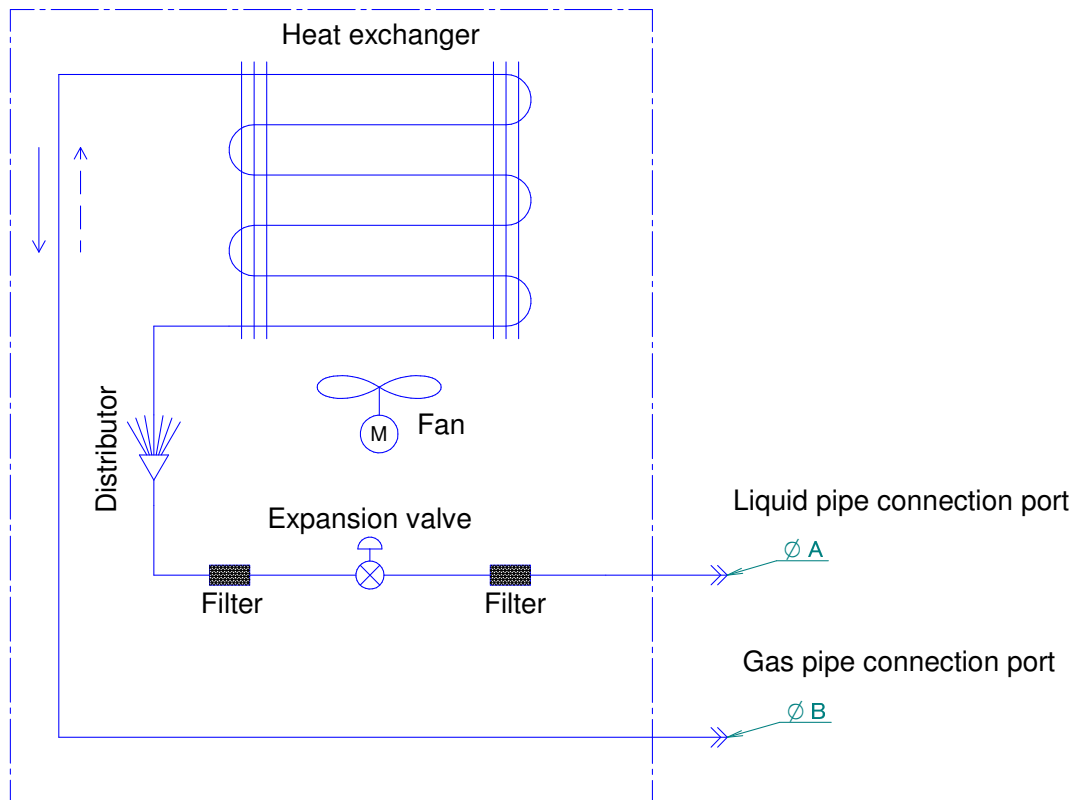

Refrigerant flow

Cooling
Heating

Model	A	B
FXKA20AMVEB	6.4	9.5
FXKA25AMVEB	6.4	9.5
FXKA32AMVEB	6.4	9.5
FXKA40AMVEB	6.4	12.7
FXKA50AMVEB	6.4	12.7
FXKA63AMVEB	6.4	12.7

4D146806

10 Sound data

10 - 1 Sound Power Spectrum

FXKA20A
FXKQ20A

Cooling mode

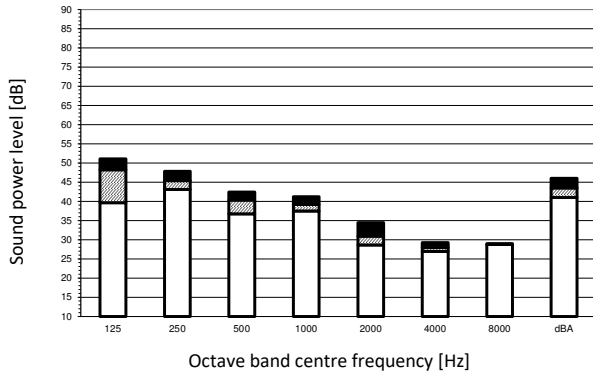

Heating mode

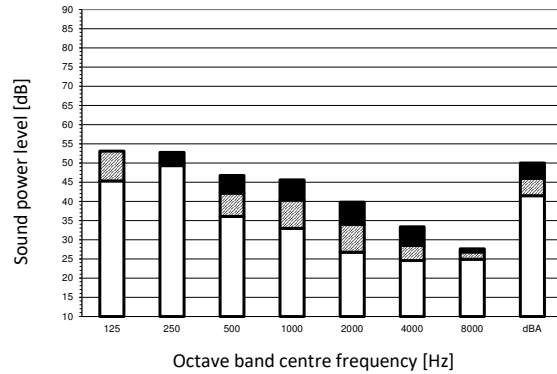

Legend

- A Scale
- B Fan speed: High
- C Fan speed: Medium
- D Fan speed: Low

Notes

- 1) dBA = A-weighted sound power level (A scale according to IEC).
- 2) Reference acoustic power 0 dB = $-10E-6-\mu W$
- 3) Measured according to ISO 3744

Cooling		Total dB	
A	B	C	D
dBA	46,0	43,5	41,0

Heating		Total dB	
A	B	C	D
dBA	50,0	46,0	41,5

4D151077

FXKA25A
FXKQ25A

Cooling mode

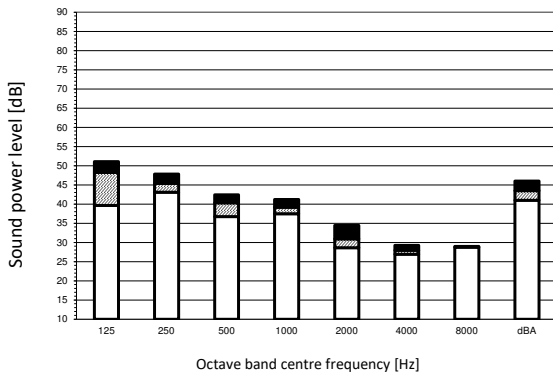

Heating mode

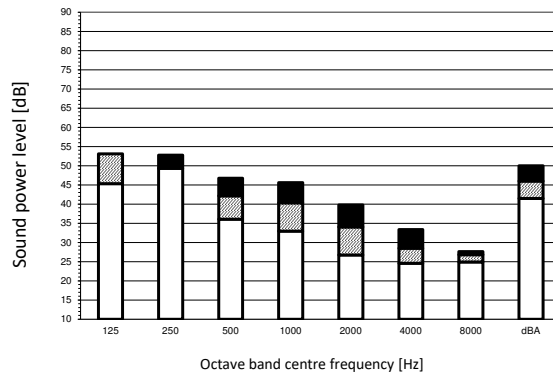

Legend

- A Scale
- B Fan speed: High
- C Fan speed: Medium
- D Fan speed: Low

Notes

- 1) dBA = A-weighted sound power level (A scale according to IEC).
- 2) Reference acoustic power 0 dB = $-10E-6-\mu W$
- 3) Measured according to ISO 3744

Cooling		Total dB	
A	B	C	D
dBA	46,0	43,5	41,0

Heating		Total dB	
A	B	C	D
dBA	50,0	46,0	41,5

4D151061

10 Sound data

10 - 1 Sound Power Spectrum

10

FXKA32A
FXKQ32A

Cooling mode

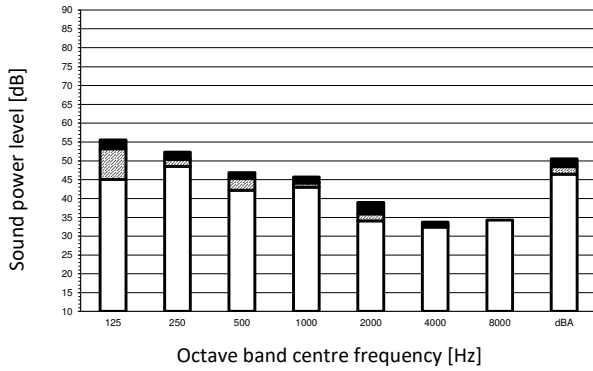

Heating mode

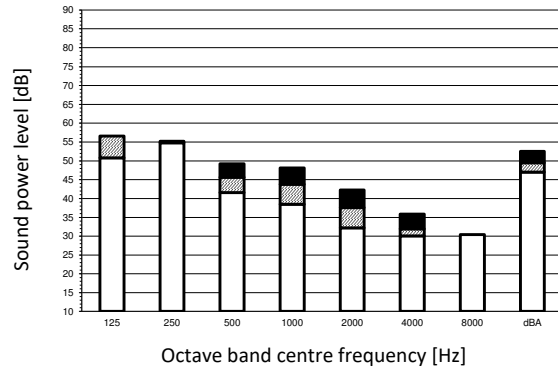

Legend

- A Scale
- B Fan speed: High
- C Fan speed: Medium
- D Fan speed: Low

Notes

- 1) dBA = A-weighted sound power level (A scale according to IEC).
- 2) Reference acoustic power 0 dB = $\cdot 10E-6 \mu W$
- 3) Measured according to ISO 3744

Cooling	Total dB		
A	B	C	D
dBA	50,5	48,5	46,5

Heating	Total dB		
A	B	C	D
dBA	52,5	49,5	47,0

4D151062

FXKA40A
FXKQ40A

Cooling mode

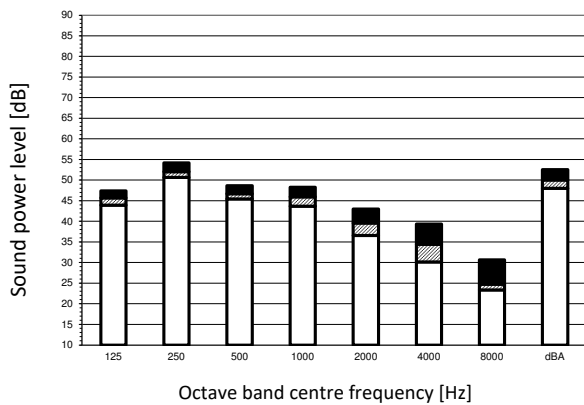

Heating mode

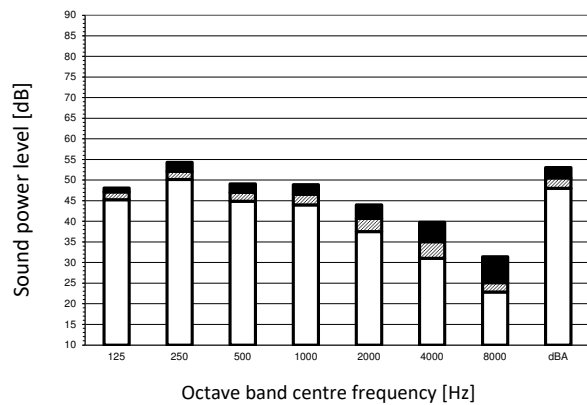

Legend

- A Scale
- B Fan speed: High
- C Fan speed: Medium
- D Fan speed: Low

Notes

- 1) dBA = A-weighted sound power level (A scale according to IEC).
- 2) Reference acoustic power 0 dB = $\cdot 10E-6 \mu W$
- 3) Measured according to ISO 3744

Cooling	Total dB		
A	B	C	D
dBA	52,5	50,0	48,0

Heating	Total dB		
A	B	C	D
dBA	53,0	50,5	48,0

4D151063

10 Sound data

10 - 1 Sound Power Spectrum

FXKA50A
FXKQ50A

Cooling mode

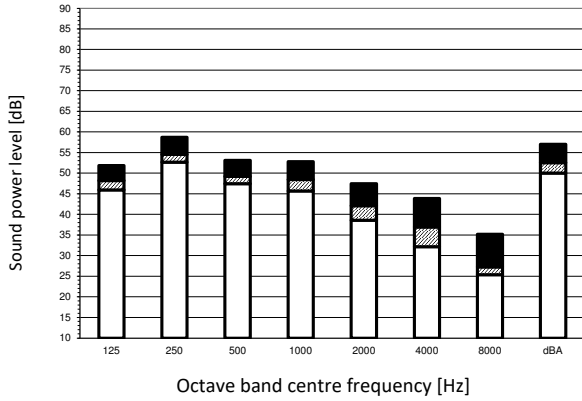

Heating mode

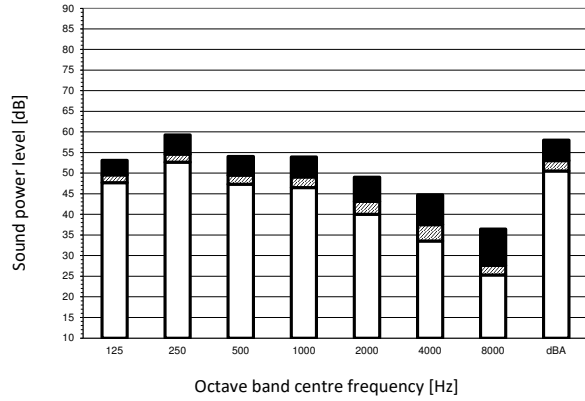

Legend

- A Scale
- B Fan speed: High
- C Fan speed: Medium
- D Fan speed: Low

Notes

- 1) dBA = A-weighted sound power level (A scale according to IEC).
- 2) Reference acoustic power 0 dB = $-10E-6 \mu W$
- 3) Measured according to ISO 3744

Cooling	Total dB			
A	B	C	D	
dBA	57,0	52,5	50,0	

Heating	Total dB			
A	B	C	D	
dBA	58,0	53,0	50,5	

4D151064

FXKA63A
FXKQ63A

Cooling mode

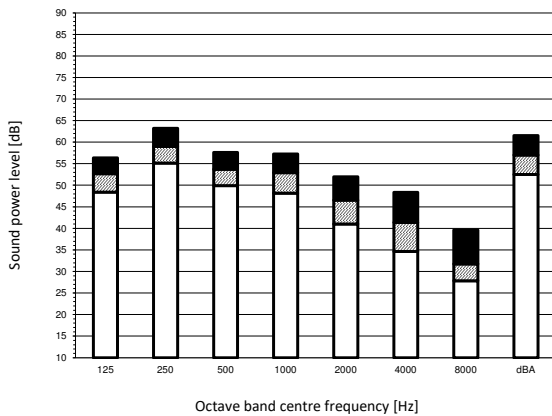

Heating mode

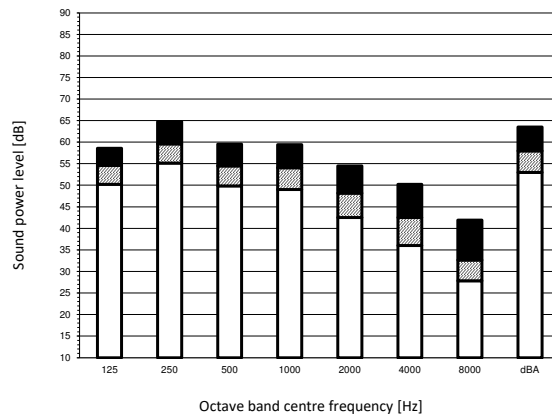

Legend

- A Scale
- B Fan speed: High
- C Fan speed: Medium
- D Fan speed: Low

Notes

- 1) dBA = A-weighted sound power level (A scale according to IEC).
- 2) Reference acoustic power 0 dB = $-10E-6 \mu W$
- 3) Measured according to ISO 3744

Cooling	Total dB			
A	B	C	D	
dBA	61,5	57,0	52,5	

Heating	Total dB			
A	B	C	D	
dBA	63,5	58,0	53,0	

4D151065

10 Sound data

10 - 2 Sound Pressure Spectrum

10

FXKA20A
FXKQ20A

Cooling mode

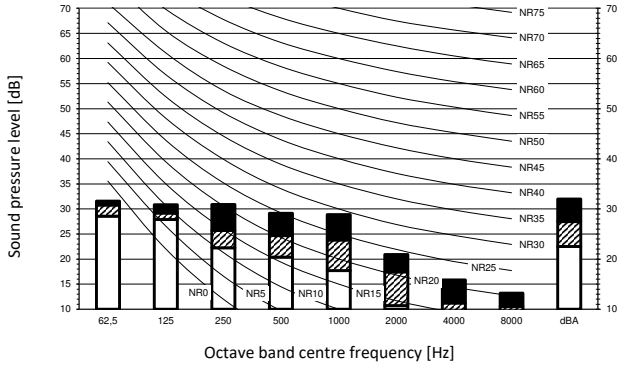

Heating mode

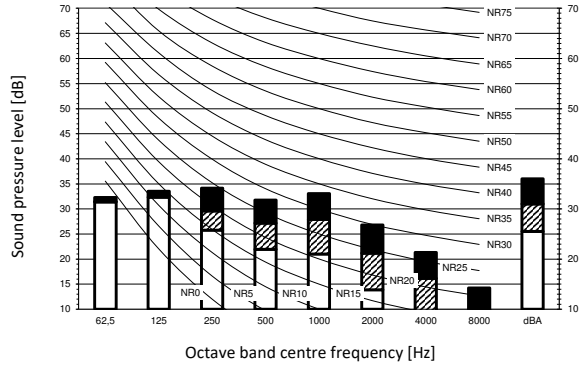

Legend

dBA = A-weighted sound pressure level (A scale according to IEC).

- A Scale
- B Fan speed: High
- C Fan speed: Medium
- D Fan speed: Low

Cooling				Total dBA
A	B	C	D	
				dBA
32,0	27,5	22,5		

Heating				Total dBA
A	B	C	D	
				dBA
36,0	31,0	25,5		

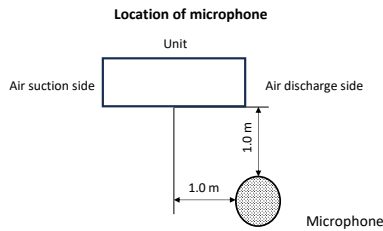

Notes

- 1) Operating conditions: power source 220-240 V/220 V 50/60 Hz; JIS standard
- 2) Background noise already taken into account.
- 3) Operating noise varies depending on operation and ambient conditions.
- 4) The operation noise measuring method is in accordance with JISC9612.
- 5) Measuring location: anechoic chamber

4D151078

FXKA25A
FXKQ25A

Cooling mode

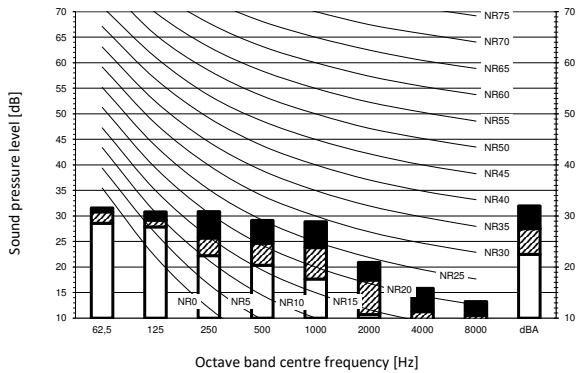

Heating mode

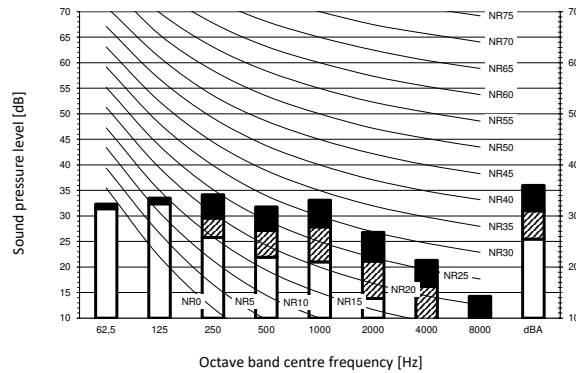

Legend

dBA = A-weighted sound pressure level (A scale according to IEC).

- A Scale
- B Fan speed: High
- C Fan speed: Medium
- D Fan speed: Low

Cooling				Total dBA
A	B	C	D	
				dBA
32,0	27,5	22,5		

Heating				Total dBA
A	B	C	D	
				dBA
36,0	31,0	25,5		

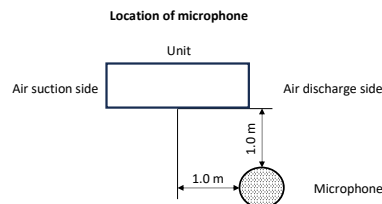

Notes

- 1) Operating conditions: power source 220-240 V/220 V 50/60 Hz; JIS standard
- 2) Background noise already taken into account.
- 3) Operating noise varies depending on operation and ambient conditions.
- 4) The operation noise measuring method is in accordance with JISC9612.
- 5) Measuring location: anechoic chamber

4D151070

10 Sound data

10 - 2 Sound Pressure Spectrum

FXKA32A
FXKQ32A

Cooling mode

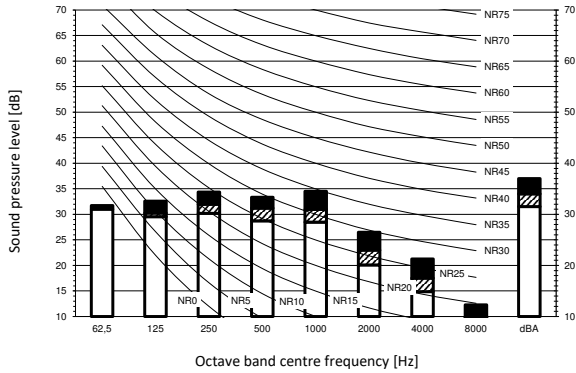

Heating mode

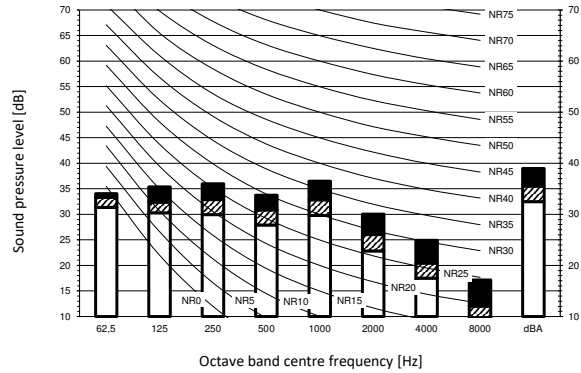

Legend

dBA = A-weighted sound pressure level (A scale according to IEC).

- A Scale
- B Fan speed: High
- C Fan speed: Medium
- D Fan speed: Low

Cooling	Total dB			
	A	B	C	D
dBA	37,0	34,0	31,5	

Heating	Total dB			
	A	B	C	D
dBA	39,0	35,5	32,5	

Location of microphone

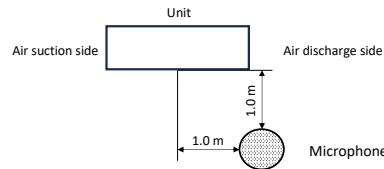

Notes

- 1) Operating conditions: power source 220-240 V/220 V 50/60 Hz; JIS standard
- 2) Background noise already taken into account.
- 3) Operating noise varies depending on operation and ambient conditions.
- 4) The operation noise measuring method is in accordance with JISC9612.
- 5) Measuring location: anechoic chamber

4D151071

FXKA40A
FXKQ40A

Cooling mode

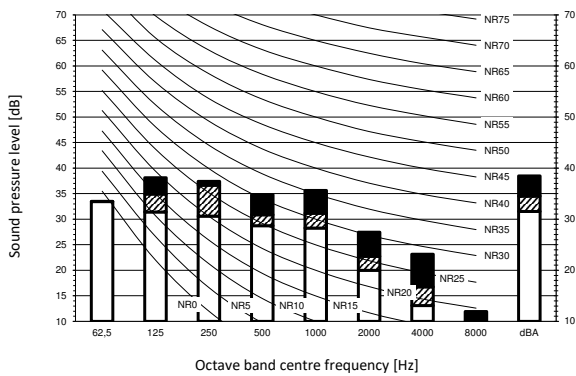

Heating mode

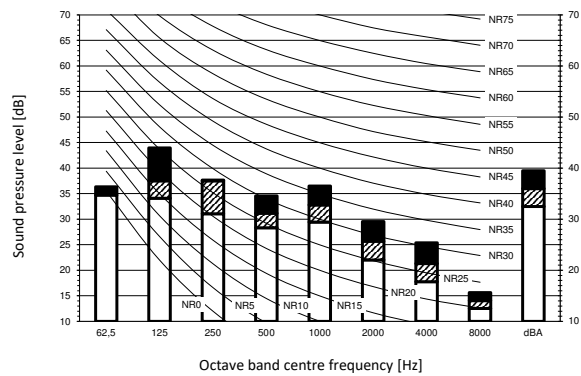

Legend

dBA = A-weighted sound pressure level (A scale according to IEC).

- A Scale
- B Fan speed: High
- C Fan speed: Medium
- D Fan speed: Low

Cooling	Total dB			
	A	B	C	D
dBA	38,5	34,5	31,5	

Heating	Total dB			
	A	B	C	D
dBA	39,5	36,0	32,5	

Location of microphone

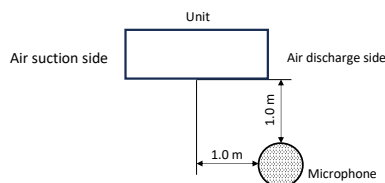

Notes

- 1) Operating conditions: power source 220-240 V/220 V 50/60 Hz; JIS standard
- 2) Background noise already taken into account.
- 3) Operating noise varies depending on operation and ambient conditions.
- 4) The operation noise measuring method is in accordance with JISC9612.
- 5) Measuring location: anechoic chamber

4D151072

10 Sound data

10 - 2 Sound Pressure Spectrum

10

FXKA50A
FXKQ50A

Cooling mode

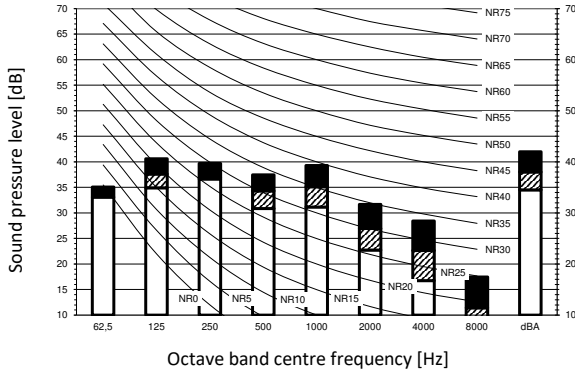

Heating mode

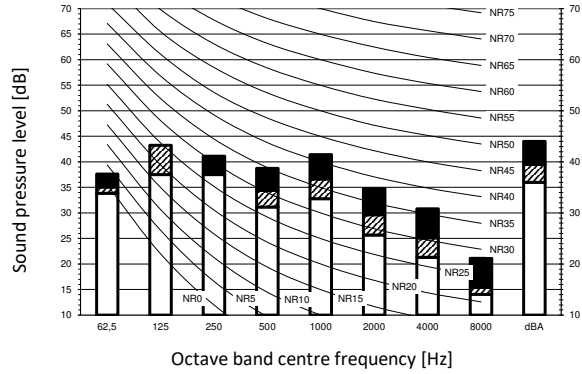

Legend

dBA = A-weighted sound pressure level (A scale according to IEC).

- A Scale
- B Fan speed: High
- C Fan speed: Medium
- D Fan speed: Low

Cooling		Total dBA	
A	B	C	D
42,0	38,0	34,5	30,5

Heating		Total dBA	
A	B	C	D
44,0	39,5	36,0	32,0

Location of microphone

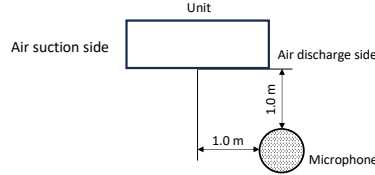

Notes

- 1) Operating conditions: power source 220-240 V/220 V 50/60 Hz; JIS standard
- 2) Background noise already taken into account.
- 3) Operating noise varies depending on operation and ambient conditions.
- 4) The operation noise measuring method is in accordance with JISC9612.
- 5) Measuring location: anechoic chamber

4D151073

FXKA63A
FXKQ63A

Cooling mode

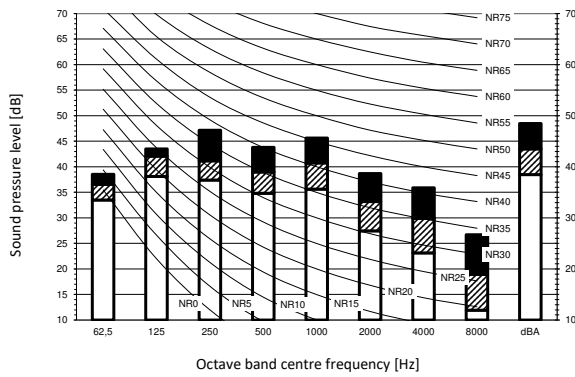

Heating mode

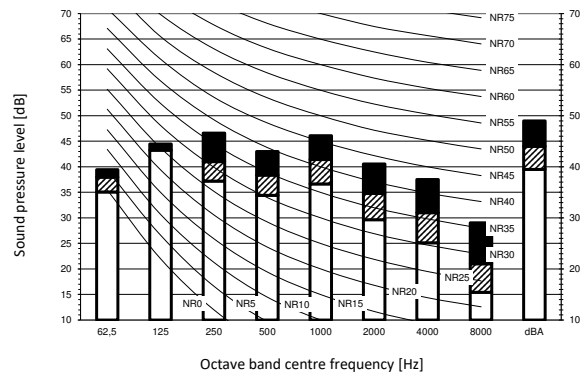

Legend

dBA = A-weighted sound pressure level (A scale according to IEC).

- A Scale
- B Fan speed: High
- C Fan speed: Medium
- D Fan speed: Low

Cooling		Total dBA	
A	B	C	D
48,5	43,5	38,5	34,5

Heating		Total dBA	
A	B	C	D
49,0	44,0	39,5	35,0

Location of microphone

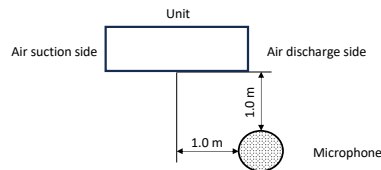

Notes

- 1) Operating conditions: power source 220-240 V/220 V 50/60 Hz; JIS standard
- 2) Background noise already taken into account.
- 3) Operating noise varies depending on operation and ambient conditions.
- 4) The operation noise measuring method is in accordance with JISC9612.
- 5) Measuring location: anechoic chamber

4D151074

11 Air flow patterns

11 - 1 Air flow pattern - Cooling and Heating

FXKA20A
FXKQ20A

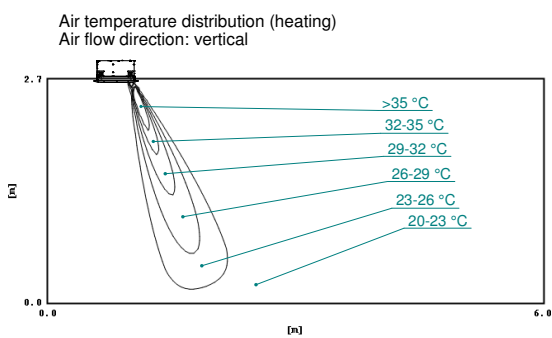
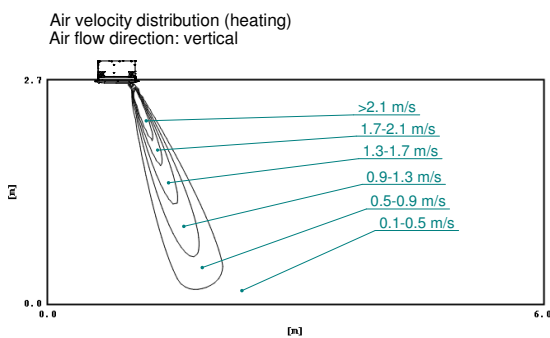
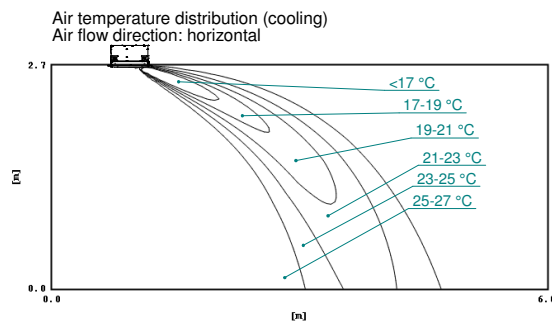
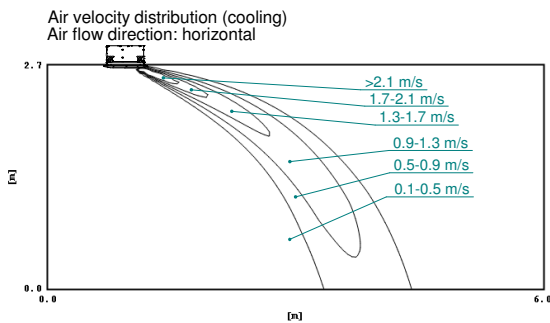

3D150986

FXKA25A
FXKQ25A

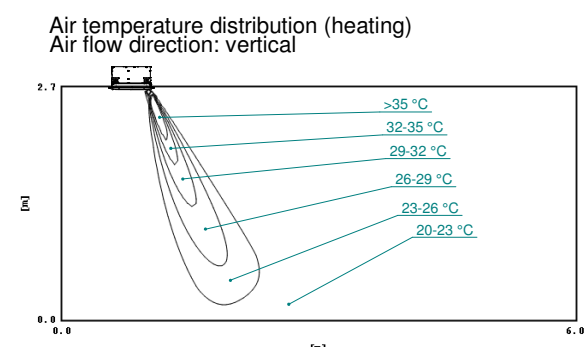
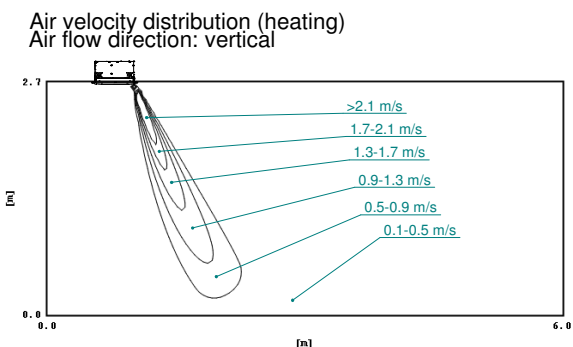
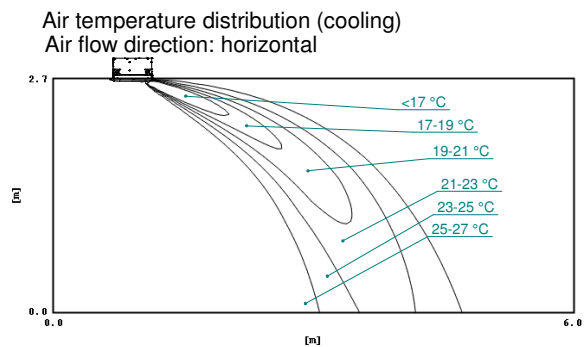
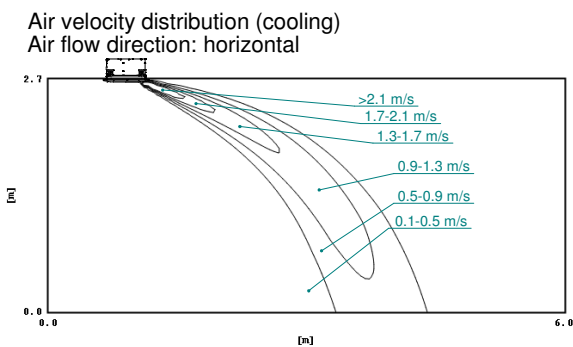

3D150987

11 Air flow patterns

11 - 1 Air flow pattern - Cooling and Heating

11

FXKA32A
FXKQ32A

Air velocity distribution (cooling)
Air flow direction: horizontal

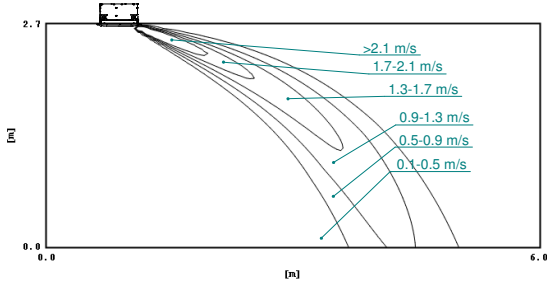

Air temperature distribution (cooling)
Air flow direction: horizontal

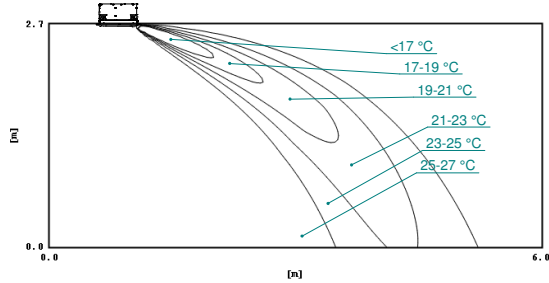

Air velocity distribution (heating)
Air flow direction: vertical

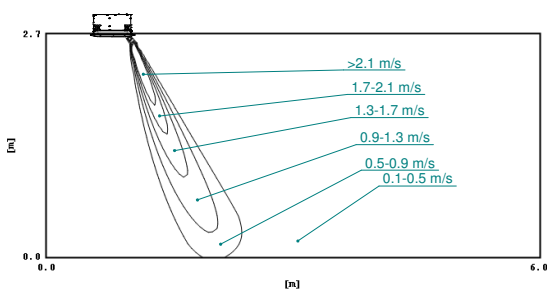

Air temperature distribution (heating)
Air flow direction: vertical

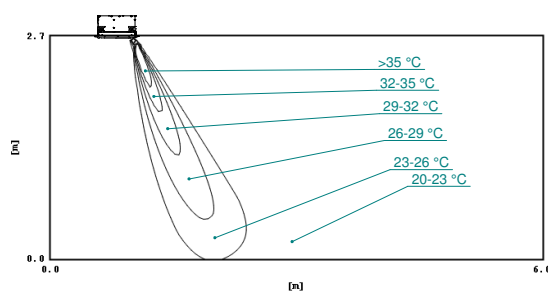

3D150988

FXKA40A
FXKQ40A

Air velocity distribution (cooling)
Air flow direction: horizontal

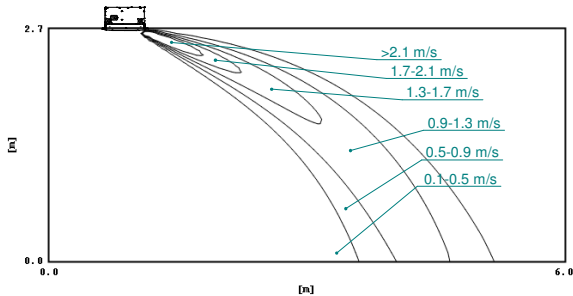

Air temperature distribution (cooling)
Air flow direction: horizontal

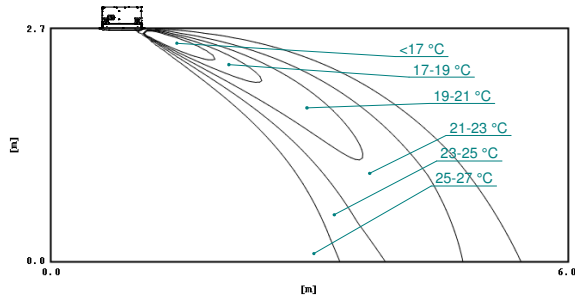

Air velocity distribution (heating)
Air flow direction: vertical

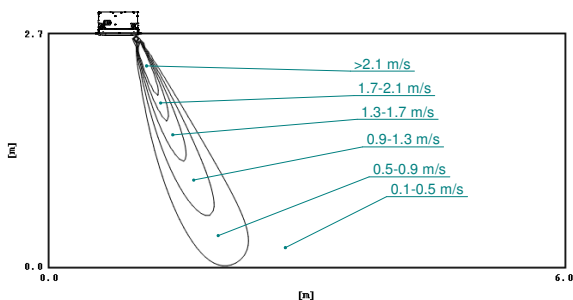

Air temperature distribution (heating)
Air flow direction: vertical

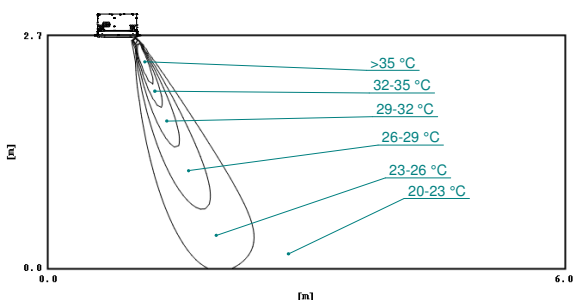

3D150989

11 Air flow patterns

11 - 1 Air flow pattern - Cooling and Heating

FXKA50A
FXKQ50A

Air velocity distribution (cooling)
Air flow direction: horizontal

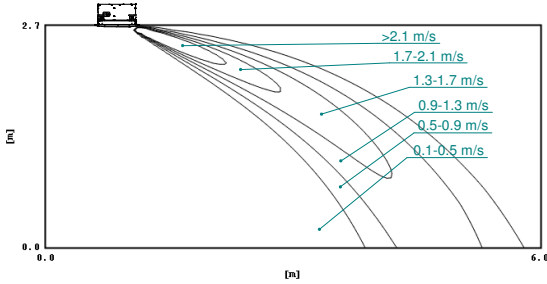

Air temperature distribution (cooling)
Air flow direction: horizontal

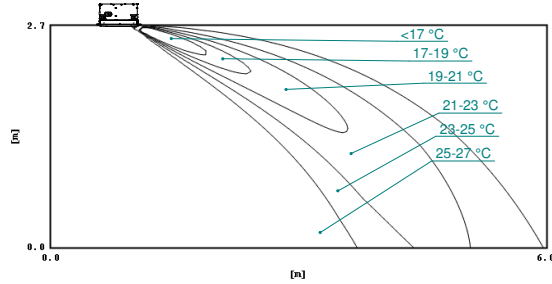

Air velocity distribution (heating)
Air flow direction: vertical

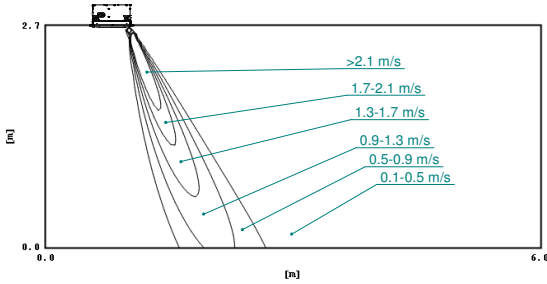

Air temperature distribution (heating)
Air flow direction: vertical

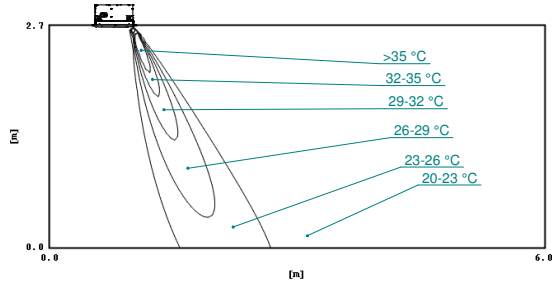

3D150990

FXKA63A
FXKQ63A

Air velocity distribution (cooling)
Air flow direction: horizontal

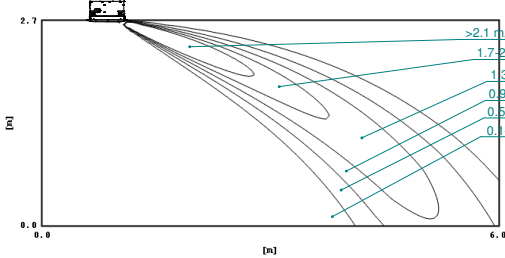

Air temperature distribution (cooling)
Air flow direction: horizontal

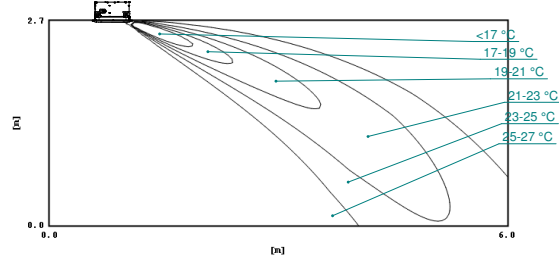

Air velocity distribution (heating)
Air flow direction: vertical

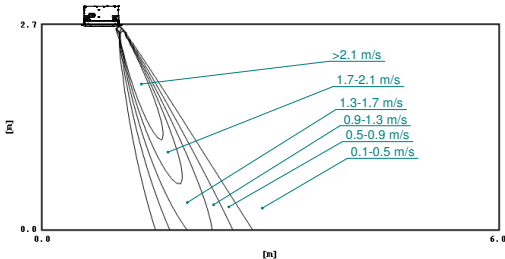

Air temperature distribution (heating)
Air flow direction: vertical

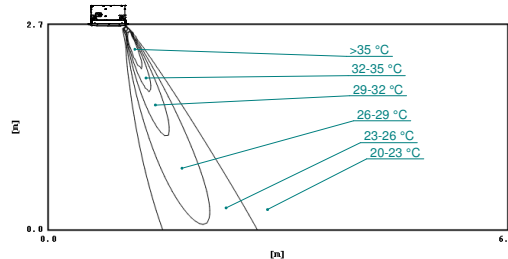

3D150991



EEDEN24

05/2024



The present leaflet is drawn up by way of information only and does not constitute an offer binding upon Daikin Europe N.V. Daikin Europe N.V. has compiled the content of this leaflet to the best of its knowledge. No express or implied warranty is given for the completeness, accuracy, reliability or fitness for particular purpose of its content and the products and services presented therein. Specifications are subject to change without prior notice. Daikin Europe N.V. explicitly rejects any liability for any direct or indirect damage, in the broadest sense, arising from or related to the use and/or interpretation of this leaflet. All content is copyrighted by Daikin Europe N.V.