

Round flow cassette
Air Conditioning
Technical Data
FXFN-B



FXFN40B2VEB
FXFN50B2VEB
FXFN63B2VEB
FXFN80B2VEB

TABLE OF CONTENTS

FXFN-B

1	Features	4
	FXFN-B	4
2	Specifications	5
3	Options	7
4	Capacity tables	9
	Cooling/Heating Capacity Tables	9
5	Dimensional drawings	10
	Dimensional Drawings with Accessories	10
	Dimensional Drawings with Fresh Air Intake	12
6	Centre of gravity	13
7	Piping diagrams	14
8	Wiring diagrams	15
	Wiring Diagrams - Single Phase	15
9	Sound data	16
	Sound Power Spectrum	16
	Sound Pressure Spectrum	18
10	Air flow patterns	20
	Air flow pattern - Cooling and Heating	20

1 Features





















1 - 1 FXFN-B

360° air discharge for optimum efficiency and comfort

1

- > Optimised design for CO2 refrigerant (R-744)
- > Optional automatic filter cleaning panel results in higher efficiency & comfort and lower maintenance costs.
- > Two optional intelligent sensors improve energy efficiency and comfort
- > Widest choice ever in decoration panels: designer panels in white (RAL9010) and black (RAL9005) and standard panels in white (RAL9010) with grey louvers or full white
- > Bigger flaps and unique swing pattern improve equal air distribution
- > Individual flap control: flexibility to suit every room layout without changing the location of the unit!
- > Optional fresh air intake
- > Standard drain pump with 675mm lift increases flexibility and installation speed



- | | | | | | | | | |
|---|---|---|--|--|--|---|---|---|
| 
Onecta app (optional) (optional) | 
Presence & floor sensor (optional) | 
Home leave operation | 
Fan only | 
Auto-cleaning filter (optional) | 
Draught prevention | 
Auto cooling-heating changeover | 
Whisper quiet | 
Ceiling soiling prevention |
| 
Individual flap control | 
Vertical auto swing | 
Fan speed steps (5 steps + auto) | 
Dry programme | 
Air filter (pre filter) | 
Weekly timer (optional) | 
Infrared remote control (optional) | 
Wired remote control | 
Centralised control (optional) |
| 
Auto-restart | 
Self diagnosis | 
Drain pump kit (standard) | | | | | | |

2 Specifications

2 - 1 Specifications

Technical specifications				FXFN40B	FXFN50B	FXFN63B	FXFN80B	
Cooling capacity	Sensible capacity	At high fan speed	kW	3.1	4.0	5.1	6.5	
		At medium fan speed	kW	2.6	3.1	3.9	5.1	
		At low fan speed	kW	2.2	2.7	3.1	3.6	
	Latent capacity	At high fan speed	kW	1.4	1.6	2.0	2.5	
		At medium fan speed	kW	1.3	1.6	1.9	2.4	
		At low fan speed	kW	1.2	1.3	1.6	1.8	
Total capacity	At high fan speed	kW	4.5	5.6	7.1	9.0		
	At medium fan speed	kW	3.9	4.7	5.8	7.5		
	At low fan speed	kW	3.4	4.0	4.7	5.4		
Heating capacity	Total capacity	At high fan speed	kW	5.0	6.3	8.0	10.0	
		At medium fan speed	kW	4.2	5.1	6.3	8.3	
		At low fan speed	kW	3.6	4.1	5.0	5.9	
Power input - 50Hz	Cooling	At high fan speed	kW	0.019	0.036	0.067	0.118	
		At medium fan speed	kW	0.015	0.025	0.040	0.074	
		At low fan speed	kW	0.013	0.018	0.025	0.041	
	Heating	At high fan speed	kW	0.019	0.036	0.067	0.118	
		At medium fan speed	kW	0.015	0.025	0.040	0.074	
		At low fan speed	kW	0.013	0.018	0.025	0.041	
Power input - 60Hz	Cooling	At high fan speed	kW	0.019	0.036	0.067	0.118	
	Heating	At high fan speed	kW	0.019	0.036	0.067	0.118	
Dimensions	Unit	Height	mm	246			288	
		Width	mm	840				
		Depth	mm	840				
	Packed unit	Height	mm	260			300	
		Width	mm	882				
		Depth	mm	882				
Weight	Unit	kg	26			29		
	Packed unit	kg	29			32		
Casing	Colour	Not painted (galvanised)						
	Material	Galvanized steel plate						
Heat exchanger	Inside length	mm	2,017					
	Outside length	mm	2,048					
	Rows	Quantity	3					
	Fin pitch	mm	1.20					
	Passes	Quantity	8			12		
	Face area	m ²	0.398			0.512		
Heat exchanger	Stages	Quantity	14			18		
	Empty tubeplate hole	Quantity	0					
	Tube type	5Bare t0.46						
	Fin	Type	Multi slit fin					
Fan	Type	Turbo fan						
	Quantity	1						
	Air flow rate - 50Hz	Cooling	At high fan speed	m ³ /min	15.5	21.0	26.8	35.5
			At medium fan speed	m ³ /min	13.5	18.0	22.0	29.5
			At low fan speed	m ³ /min	11.5	15.0	18.0	23.5
		Heating	At high fan speed	m ³ /min	15.5	21.0	26.8	35.5
			At medium fan speed	m ³ /min	13.5	18.0	22.0	29.5
			At low fan speed	m ³ /min	11.5	15.0	18.0	23.5
	Air flow rate - 60Hz	Cooling	At high fan speed	cfm	547	742	946	1,254
			At medium fan speed	cfm	477	636	777	1,042
Heating		At high fan speed	cfm	547	742	946	1,254	
		At medium fan speed	cfm	477	636	777	1,042	
At low fan speed	cfm	406	530	636	830			
Fan motor	Drive	Variable speed drive (VSD)						
Sound power level	Cooling	At high fan speed	dBA	53.0	57.0	62.0	66.0	
		At medium fan speed	dBA	51.0	55.0	60.0	64.0	
		At low fan speed	dBA	49.0	53.0	58.0	62.0	
	Heating	At high fan speed	dBA	54.0	58.0	63.0	67.0	
		At medium fan speed	dBA	52.0	56.0	61.0	65.0	
		At low fan speed	dBA	50.0	54.0	59.0	63.0	
Sound pressure level	Cooling	At high fan speed	dBA	35.0	39.0	44.0	48.0	
		At medium fan speed	dBA	33.0	37.0	42.0	46.0	
		At low fan speed	dBA	31.0	35.0	40.0	44.0	
	Heating	At high fan speed	dBA	36.0	40.0	45.0	49.0	
		At medium fan speed	dBA	34.0	38.0	43.0	47.0	
		At low fan speed	dBA	32.0	36.0	41.0	45.0	

2 Specifications

2 - 1 Specifications

2

Technical specifications				FXFN40B	FXFN50B	FXFN63B	FXFN80B	
Fan motor	Quantity			1				
	Speed	Steps			5			
		Cooling	High	rpm	390	503	623	753
	Low		rpm	307	379	441	521	
	Heating	High	rpm	390	503	623	753	
Low		rpm	307	379	441	521		
Fan motor	Output	Max	W	106				
Refrigerant	Type			R-744				
	GWP			1.0				
Piping connections	Liquid	Type			Braze connection			
		OD	mm	9.52				
	Gas	Type			Braze connection			
		OD	mm	12.7				
	Drain			VP25 (I.D. 32/O.D. 25)				
Heat insulation			Foamed polystyrene / Foamed polyethylene					
Sound absorbing insulation			Foamed polyurethane					
Decoration panel	Model			BYCQ140E2W1/BYCQ140E2W1W/BYCQ140E2W1B				
	Dimensions	Height	mm	65				
		Width	mm	950				
		Depth	mm	950				
	Weight			5.5				
Decoration panel 2	Model			BYCQ140E2GFW1 / BYCQ140E2GFW1B				
	Dimensions	Height	mm	148				
		Width	mm	950				
		Depth	mm	950				
	Weight			10.3				
Decoration panel 3	Model			BYCQ140E2P / BYCQ140E2PB				
	Dimensions	Height	mm	106				
		Width	mm	950				
		Depth	mm	950				
	Weight			6.5				
Air filter	Type			Resin net				
Safety devices	Item	01			PC board fuse			
		02			Fan motor overcurrent protector			
Control systems	Infrared remote control			BRC7FA532F / BRC7FA532FB / BRC7FB532F / BRC7FB532FB				
	Wired remote control			BRC1H52W/S/K				

Standard accessories: Washer for hanger bracket;Quantity: 8;

Standard accessories: Wire clamp material;Quantity: 7;

Standard accessories: Clamp for drain hose;Quantity: 1;

Standard accessories: Clamps;Quantity: 1;

Standard accessories: Drain hose;Quantity: 1;

Standard accessories: Installation and operation manual;Quantity: 1;

Standard accessories: Installation guide;Quantity: 1;

Standard accessories: Insulation for fitting;Quantity: 2;

Standard accessories: Screws;Quantity: 4;

Standard accessories: Sealing pad;Quantity: 1;

Electrical specifications				FXFN40B	FXFN50B	FXFN63B	FXFN80B	
Power supply	Name			VE				
	Phase			1~				
	Frequency	Hz			50/60			
	Voltage	V			220-240/220			
Current - 50Hz	Minimum circuit amps (MCA)	A	0.4	0.7	0.9	1.4		
	Maximum fuse amps (MFA)	A	6					
	Full load amps (FLA) Total	A	0.3	0.6	0.8	1.3		
Current - 60Hz	Minimum circuit amps (MCA)	A	0.4	0.7	0.9	1.4		
	Maximum fuse amps (MFA)	A	6					
	Full load amps (FLA) Total	A	0.3	0.6	0.8	1.3		

Values are valid for the factory setting. |

Cooling: indoor temp. 27°CDB, 19°CWB; outdoor temp. 35°CDB |

Heating: indoor temp. 20°CDB; outdoor temp. 7°CDB, 6°CWB |

The sound power level is an absolute value indicating the power which a sound source generates. |

Voltage range: units are suitable for use on electrical systems where voltage supplied to unit terminal is not below or above listed range limits. |

Maximum allowable voltage range variation between phases is 2%. |

MCA/MFA: MCA = 1.1 x FLA |

Instead of a fuse, use a circuit breaker |

Select wire size based on the value of MCA |

BYCQ140E2W1: pure white standard panel with grey louvers; BYCQ140E2W1W: pure white standard panel with white louvers; BYCQ140E2W1B: black standard panel with black louvers. |

The BYCQ140E2W1W has white insulations. Be informed that formation of dirt on white insulation is visibly stronger and that it is consequently not advised to install the BYCQ140E2W1W decoration panel in environments exposed to concentrations of dirt. |

Contains fluorinated greenhouse gases

3 Options

3 - 1 Options

FXFN-B

Option kit		Product name	Availability
			FXFN60-112A2VEB
Decoration panel	Standard	BYCQ140E2W1	✓
	White	BYCQ140E2W1W ②	✓
	Black	BYCQ140E2W1B	✓
High-efficiency filter	-1- filter(s) in the box	BAF552AA160 ⑳㉔	✓
	-5- filter(s) in the box	BAF552AA160-5 ⑳㉔	✓
	-10- filter(s) in the box	BAF552AA160-10 ⑳㉔	✓
Designer decoration panel		BYCQ140E2P ㉑	✓
Designer decoration panel	Black	BYCQ140E2PB ㉑	✓
Self-cleaning decoration panel (with fine filter)		BYCQ140E2GFW1 ㉓㉔㉑	✓
Self-cleaning decoration panel (with fine filter)	Black	BYCQ140E2GFW1B ㉓㉔㉑	✓
Long-life replacement filter		KAF551D160 ㉑	✓
Chamber [part of fresh air intake kit (-20-% fresh air)]		KDDP55C160-1 ㉓㉑	✓
Diffuser from chamber to duct [part of fresh air intake kit (-20-% fresh air)]		KDDP55D160-2 ㉓㉑	✓
Air discharge outlet sealing member		KDBHQ56B140 ㉑	✓
Sensor kit		BRYQ140B8 ③	✓
Sensor kit	Black	BRYQ140B8B ③	✓
Sensor kit (for designer decoration panel)		BRYQ140C8 ⑮	✓
Sensor kit (for designer decoration panel)	Black	BRYQ140C8B ⑮	✓
Wireless remote control		BRC7FA532F ③⑮⑭⑰	✓
Wireless remote control	Black	BRC7FA532FB ③⑮⑭⑰	✓
Wireless remote control (for designer decoration panel)		BRC7FB532F ③⑮⑱⑰	✓
Wireless remote control (for designer decoration panel)	Black	BRC7FB532FB ③⑮⑱⑰	✓
Wired remote control		BRC1H52W/S/K	✓
Wiring adaptor for electrical appendices -1-		KRP1BA58 ⑬	✓
Wiring adaptor for electrical appendices -2-		KRP4A53 ⑬	✓
Wiring adaptor (hour meter)		EKRP1C12 ⑬	✓
Remote sensor		KRCS01-5B	✓
Installation box for adaptor PCB		KRP1H98A ③	✓
Central remote control		DCS302C51	✓
Unified ON/OFF controller		DCS301B51	✓
Electrical box with earth terminal (-2- blocks)		KJB212A	✓
Electrical box with earth terminal (-3- blocks)		KJB311A	✓
Digital input adaptor		BRP7A53 ⑬⑭	✓
Intelligent Touch Manager		DCM601B51	✓
Intelligent Tablet Controller		DCM601A51	✓
Wire harness for external wireless temperature sensor		EKEWTSC-2 ⑱	✓
Wireless room thermostat		K.RSS ⑱	✓
PCB for multi-tenant indoor units		DTA114A61 ⑫⑲	✓
WLAN adaptor for smartphones		BRP069C51	✓
Daikin Cloud Plus with Edge		DGE601A51, DGE602A51	✓
BACnet interface		DMS502B51	✓
Installation box for adaptor PCB		KRP1BC101	✓
External control adaptor for outdoor unit		DTA104A62 ⑫⑲	✓

For notes and symbols, refer to page -2-.

3D157207

3 Options

3 - 1 Options

3

FXFN-B

- ① All options are kits
- ② This option has white insulation.
Be aware that dirt formation is more easily visible on white insulation.
It is recommended not to install this option in environments with a high concentration of dirt.
- ③ To be able to control option -BYCQ140E2GFW1 / BYCQ140E2GFW1B-, controller -BRC1H52- is required.
- ④ This option cannot be used with -multi- and -non-inverter split outdoor- models.
- ⑤ This option is suitable for all applications, except for use in environments that are greasy, or have high humidity.
- ⑥ This option cannot be combined with -BYCQ140E2GFW1- or -BYCQ140E2GFW1B-.
- ⑦ Both parts of the fresh air intake kit are required for each unit.
- ⑧ Only possible in combination with -BYCQ140E2W1 / BYCQ140E2W1W / BYCQ140E2GFW1-
- ⑨ Only possible in combination with -BYCQ140E2W1B / BYCQ140E2GFW1B-
- ⑩ Only possible in combination with -BYCQ140E2W1 / BYCQ140E2W1W-
- ⑪ Only possible in combination with -BYCQ140E2W1B-
- ⑫ Requires installation box for adaptor PCB -KRP1BC101-.
- ⑬ Requires installation box for adaptor PCB -KRP1H98A-.
- ⑭ Only possible in combination with remote control -BRC1H52-.
- ⑮ Only possible in combination with -BYCQ140E2P-
- ⑯ Only possible in combination with -BYCQ140E2PB-
- ⑰ The active airflow circulation function is not available for this controller.
- ⑱ -EKEWTSC-2- is a wire harness for the connection of option -K.RSS-.
-K.RSS- is not an official option. Sales for this option are an SBU responsibility.
- ⑲ This option cannot be combined with -BYCQ140E2GFW1- or -BYCQ140E2GFW1B-.
- ⑳ Option cannot be combined with -BYCQ140E2P, BYCQ140E2PB, BYCQ140E2GFW1, BYCQ140E2GFW1B, KAF5511D160, KDDP55C160-1, KDDP55D160-2, KDBHQ56B140-.
- ㉑ Option cannot be combined with -BAF552AA160, BAF552AA160-5, BAF552AA160-10-.
- ㉒ Do NOT install in places that require a high ceiling mode setting and 2/3 way blow mode setting of the indoor unit.

3D157207

4 Capacity tables

4 - 1 Cooling/Heating Capacity Tables

FXFN-B

Cooling

Unit size	Fan speed	Indoor air temperature													
		14.0 [°C WB]		16.0 [°C WB]		18.0 [°C WB]		19.0 [°C WB]		20.0 [°C WB]		22.0 [°C WB]		24.0 [°C WB]	
		TC	SHC	TC	SHC	TC	SHC	TC	SHC	TC	SHC	TC	SHC	TC	SHC
40	H	2.6	2.0	3.3	2.5	4.1	2.9	4.5	3.1	4.9	3.1	5.8	3.4	6.7	3.6
	M	Correction factor -0.87 × H-													
	L	Correction factor -0.76 × H-													
50	H	3.2	2.6	4.1	3.1	5.1	3.6	5.6	4.0	6.1	3.9	7.2	4.2	8.4	4.5
	M	Correction factor -0.84 × H-													
	L	Correction factor -0.71 × H-													
63	H	4.1	3.4	5.2	4.0	6.5	4.7	7.1	5.1	7.8	5.0	9.2	5.4	10.6	5.8
	M	Correction factor -0.82 × H-													
	L	Correction factor -0.66 × H-													
80	H	5.2	4.2	6.6	5.1	8.2	5.9	9.0	6.5	9.8	6.4	11.6	6.9	13.5	7.3
	M	Correction factor -0.83 × H-													
	L	Correction factor -0.68 × H-													

Notes

- TC: Total capacity [kW]
SHC: Sensible heat capacity [kW]
H: High
M: Medium
L: Low
- Outdoor temperature: 35°C DB

Heating

Unit size	Fan speed	Indoor air temperature									
		15.0 [°C DB]		18.0 [°C DB]		20.0 [°C DB]		22.0 [°C DB]		24.0 [°C DB]	
		TC	TC	TC	TC	TC	TC	TC	TC		
20	H	6.2	5.6	5.0	4.7	4.4	3.8				
	M	Correction factor -0.84 × H-									
	L	Correction factor -0.72 × H-									
25	H	7.8	7.1	6.3	5.9	5.5	4.8				
	M	Correction factor -0.81 × H-									
	L	Correction factor -0.65 × H-									
32	H	9.9	9.0	8.0	7.5	7.0	6.0				
	M	Correction factor -0.79 × H-									
	L	Correction factor -0.63 × H-									
40	H	12.4	11.2	10.0	9.4	8.8	7.5				
	M	Correction factor -0.83 × H-									
	L	Correction factor -0.59 × H-									

Notes

- TC: Total capacity [kW]
H: High
M: Medium
L: Low
- Outdoor temperature: 7°C DB / 6°C WB

4D156867

5 Dimensional drawings

5 - 1 Dimensional Drawings with Accessories

5

FXFN-B STANDARD PANEL

Notes

- Location of nameplate
The unit nameplate is located on the control box cover.
The decoration panel nameplate is located on the piping-side panel frame, under the corner cover.
- When installing optional accessories, refer to their respective documentation.
- Make sure the distance between the ceiling and the cassette does not exceed 35 mm.
The maximum ceiling opening is 910 mm.
- When the conditions in the ceiling exceed 30°C ambient temperature and 80% relative humidity, or when fresh air is introduced into the ceiling, additional insulation is required (polyethylene foam, thickness > 10 mm).
- When installing a sensor kit, there will be a sensor on this location. For details, see the drawing of the sensor kit.
- When installing a wireless controller, there will be a receiver on this location. For details, see the drawing of the wireless controller.

Cassette height		Minimal installation height		Model
AA	AB	AC		
246	180	289		FXFN40/50/63B2VEB
288	180	311		FXFN80B2VEB

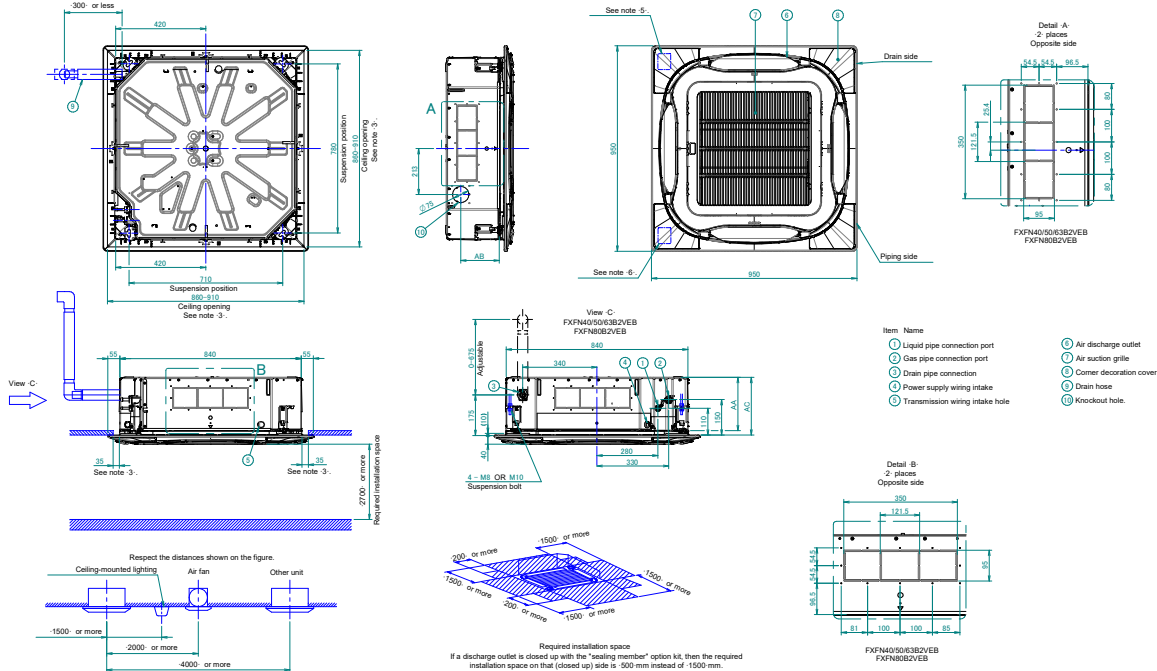

2D156432

FXFN - B SELF CLEANING PANEL

Notes

- Location of nameplate
The unit nameplate is located on the control box cover.
The decoration panel nameplate is located on the piping-side panel frame, under the corner cover.
- When installing optional accessories, refer to their respective documentation.
- Make sure the distance between the ceiling and the cassette does not exceed 35 mm.
The maximum ceiling opening is 910 mm.
- When the conditions in the ceiling exceed 30°C ambient temperature and 80% relative humidity, or when fresh air is introduced into the ceiling, additional insulation is required (polyethylene foam, thickness > 10 mm).
- When installing a sensor kit, there will be a sensor on this location. For details, see the drawing of the sensor kit.

Cassette height		Minimal installation height		Model
AA	AB	AC		
246	180	349		FXFN40/50/63B2VEB
288	180	391		FXFN80B2VEB

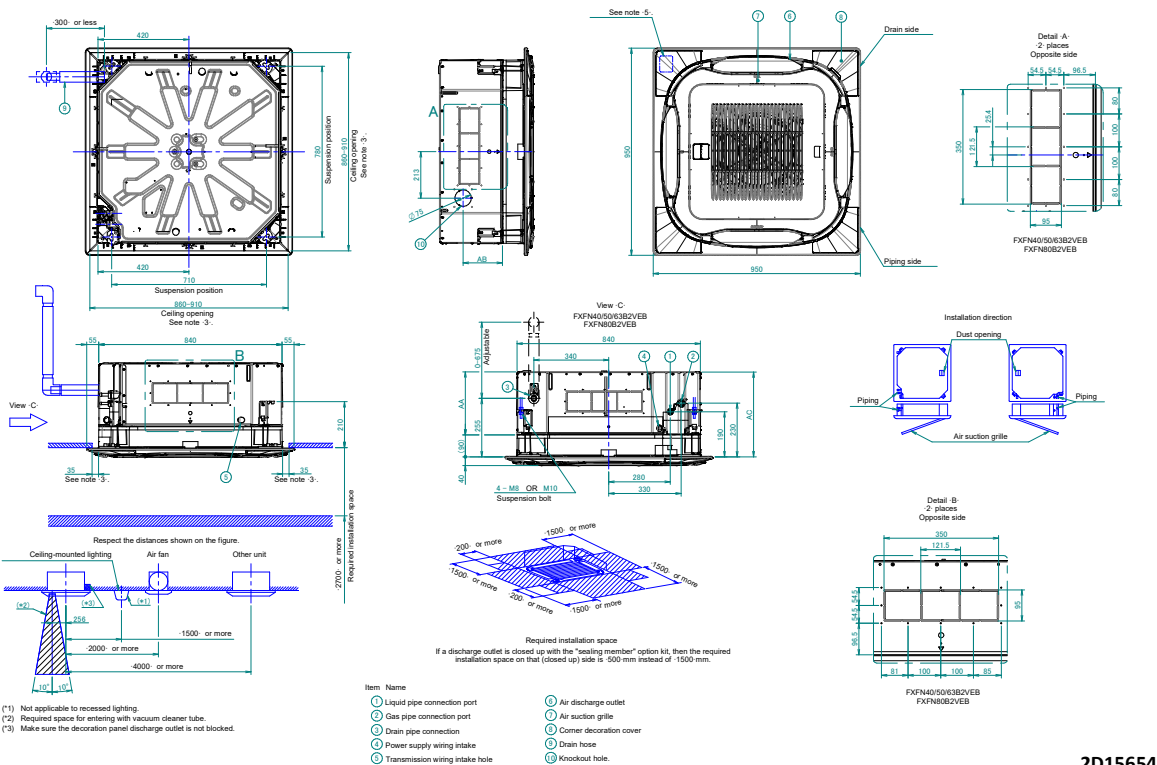

2D156545

5 Dimensional drawings

5 - 2 Dimensional Drawings with Fresh Air Intake

5

FXFN-B FRESH AIR INLET KIT

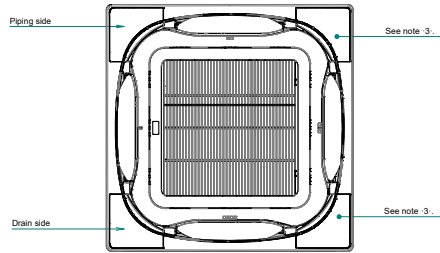
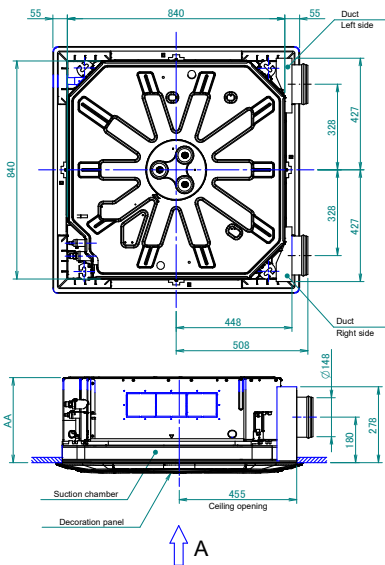

Service access panel
450 x 450 mm: or more
See note 1:

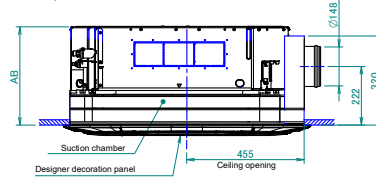
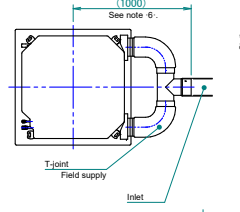
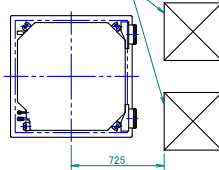

Minimal installation height		Model name
AA	AB	
277	319	FCAG35/50/60/71BVEB
		FXFQ20/25/32/40/50/63BVEB
		FXFA20/25/32/40/50/63A2VEB
		FCAG100/125/140BVEB
319	361	FXFG80/100BVEB
		FXFA80/100A2VEB
		FXFN50/71A2VEB
		FXFN40/50/63B2VEB
361	403	FCAHG71/100/125/140HVEB
		FXFQ125BVEB
		FXFA125A2VEB
		FXFN125A2VEB
		FXFN63B2VEB

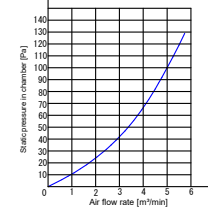

Notes

- When installing a fresh air intake kit, provide a service access panel.
- Field construction
- This corner discharge outlet needs to be closed.
- When installing a duct fan, use a wiring adapter to link the duct fan to the fan of the indoor unit.
- The intake air flow rate is recommended to be 30% of the air flow rate at high fan speed.
If the intake air flow rate is too large, the operating sound may increase, and the detection of the indoor unit suction temperature may be affected.
- This indicates the distance between the T-joint inlet and the indoor unit inlet when the T-tube is connected.

3D121741D

6 Centre of gravity

6 - 1 Centre of Gravity

FXFN-B

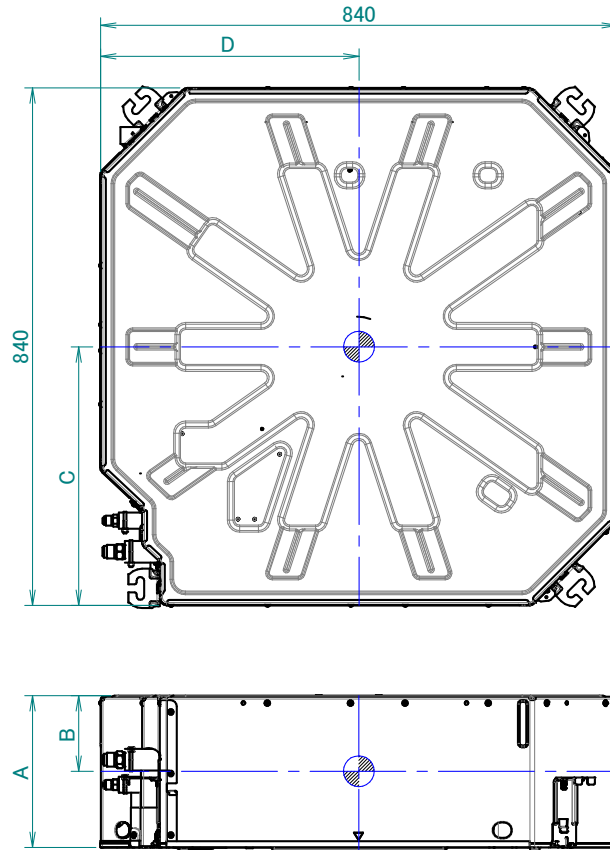

Model	A	B	C	D
FCAG35~71BVEB	204	70	400	405
FCAG100~140BVEB	246	100	400	405
FCAG71~140HVEB	288	135	400	405
FXFQ20~63BVEB, FXFA20~63A2VEB	204	70	395	400
FXFQ80~100BVEB, FXFA80~100A2VEB	246	100	395	400
FXFQ125BVEB, FXFA125A2VEB	288	135	395	400
FXFN50~71A2VEB, FXFN40~63B2VEB	246	113	408	412
FXFN112A2VEB, FXFN80B2VEB	288	120	403	415

4D121659C

7 Piping diagrams

7 - 1 Piping Diagrams

7

FXFN-B

Model	Number of passes
FXFN60/71A2VEB FXFN40/50/63B2VEB	4
FXFN112A2VEB FXFN80B2VEB	6

3x3 cassette

Refrigerant flow

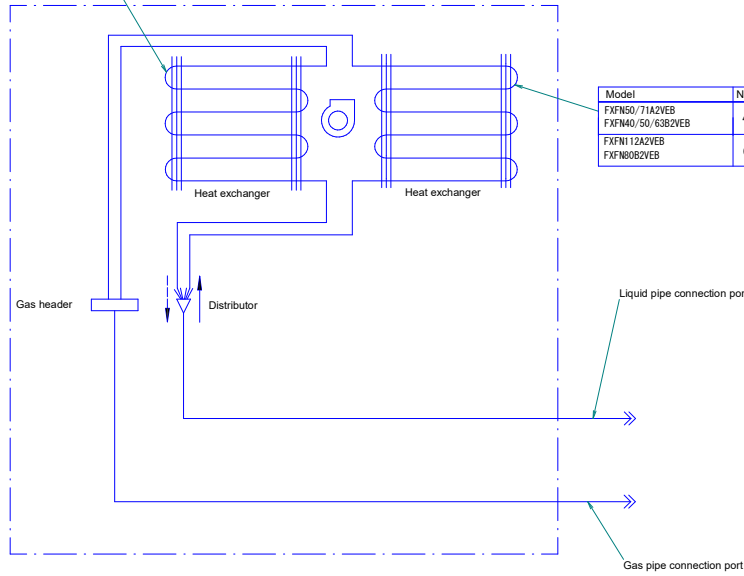

Model	Number of passes
FXFN50/71A2VEB FXFN40/50/63B2VEB	4
FXFN112A2VEB FXFN80B2VEB	6

Piping connections Ø

Model	Gas	Liquid
FXFN60/71/112A2VEB FXFN40/50/63/80B2VEB	Ø 12.70	Ø 9.52

3D135873A

8 Wiring diagrams

8 - 1 Wiring Diagrams - Single Phase

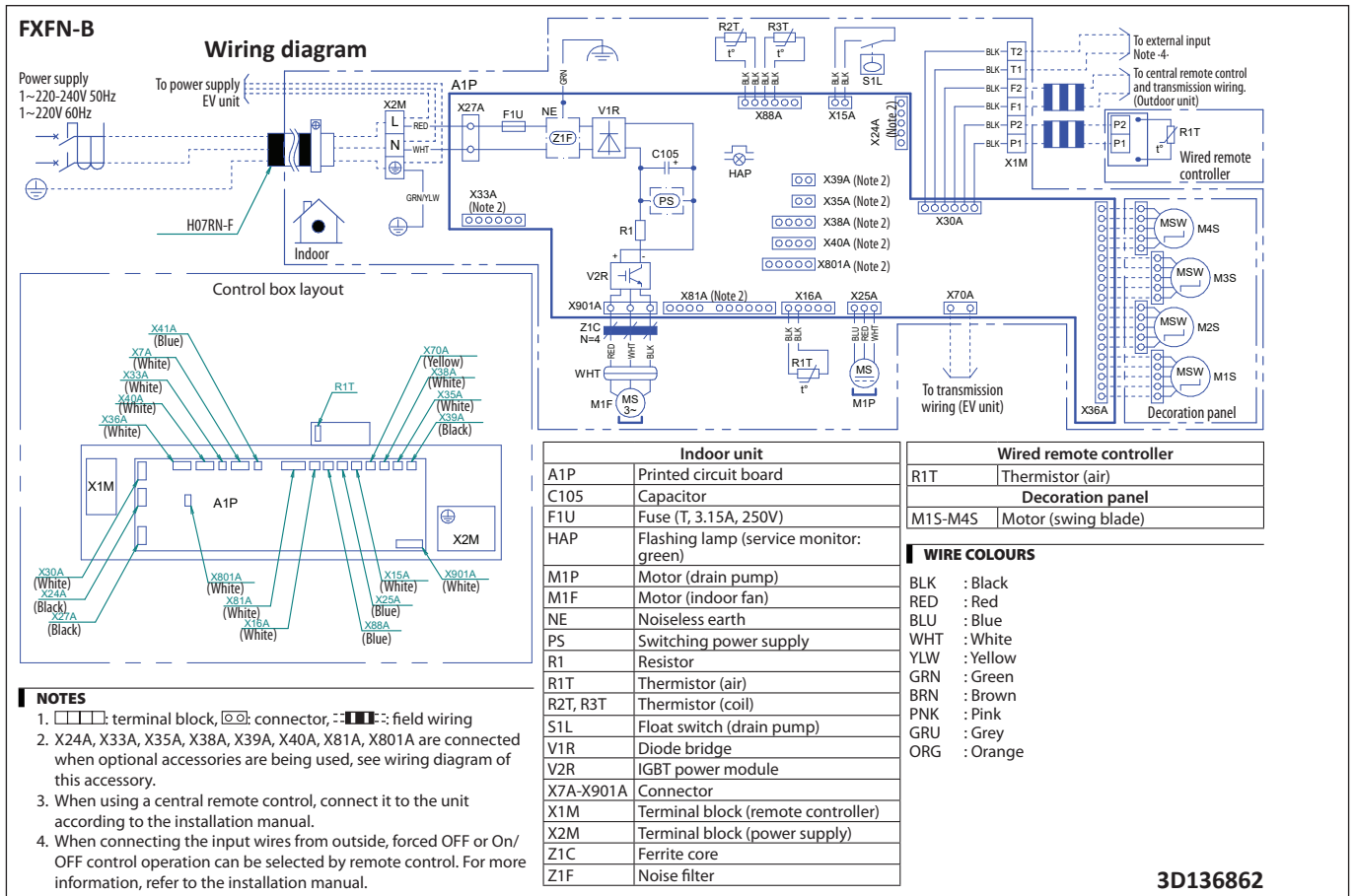

9 Sound data

9 - 1 Sound Power Spectrum

9

FXFN40B

Cooling mode

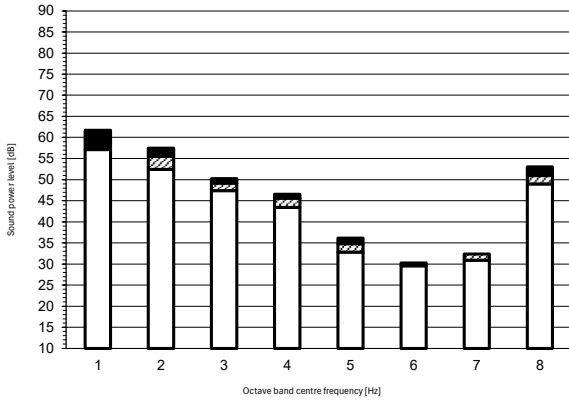

Heating mode

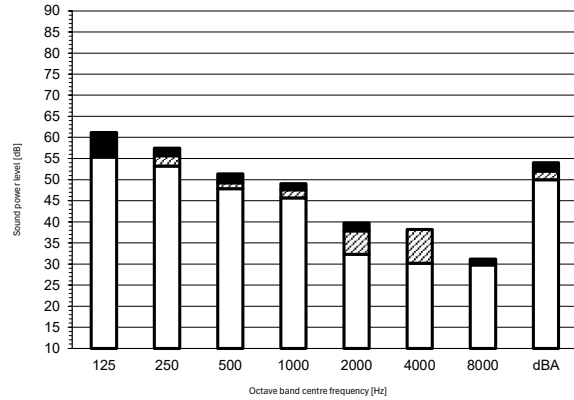

Legend

- A Scale
- B Fan speed: High
- C Fan speed: Medium
- D Fan speed: Low

Notes

- 1) dBA = A-weighted sound power level (A scale according to IEC).
- 2) Reference acoustic power 0 dB = -10E-6 μW
- 3) Measured according to ISO 3744.

Cooling				Total dB
A	B	C	D	
dBA	53,0	51,0	49,0	

Heating				Total dB
A	B	C	D	
dBA	54,0	52,0	50,0	

4D156980

FXFN50B

Cooling mode

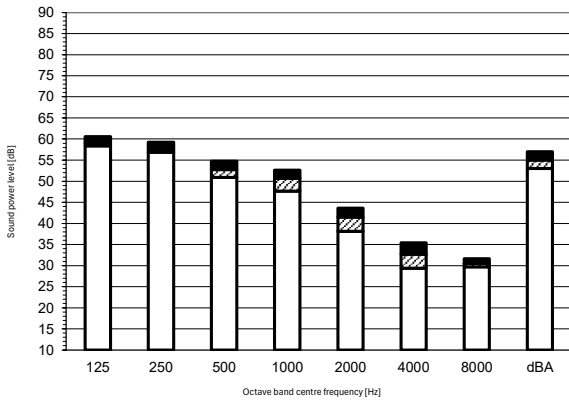

Heating mode

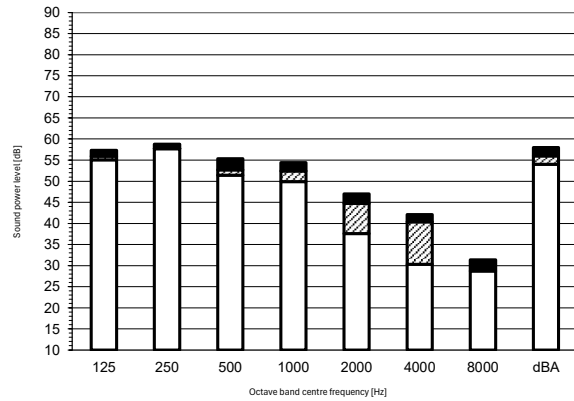

Legend

- A Scale
- B Fan speed: High
- C Fan speed: Medium
- D Fan speed: Low

Notes

- 1) dBA = A-weighted sound power level (A scale according to IEC).
- 2) Reference acoustic power 0 dB = -10E-6 μW
- 3) Measured according to ISO 3744.

Cooling				Total dB
A	B	C	D	
dBA	57,0	55,0	53,0	

Heating				Total dB
A	B	C	D	
dBA	58,0	56,0	54,0	

4D156981

9 Sound data

9 - 1 Sound Power Spectrum

FXFN63B

Cooling mode

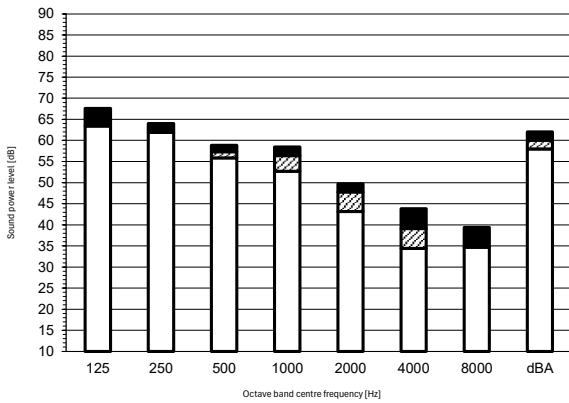

Heating mode

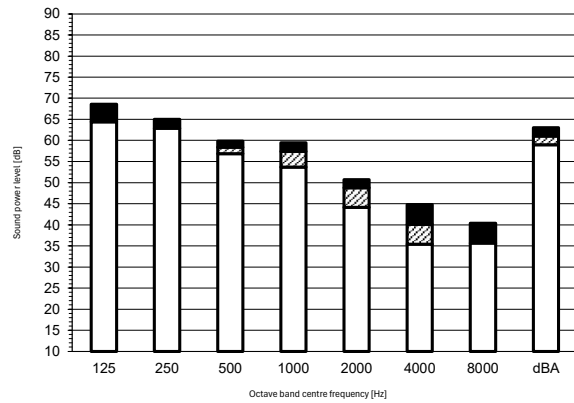

Legend

- A Scale
- B Fan speed: High
- C Fan speed: Medium
- D Fan speed: Low

Notes

- 1) dBA = A-weighted sound power level (A scale according to IEC).
- 2) Reference acoustic power 0 dB = -10E-6 μW
- 3) Measured according to ISO 3744.

Cooling				Total dB
A	B	C	D	
dBA	62,0	60,0	58,0	

Heating				Total dB
A	B	C	D	
dBA	63,0	61,0	59,0	

4D156982

FXFN80B

Cooling mode

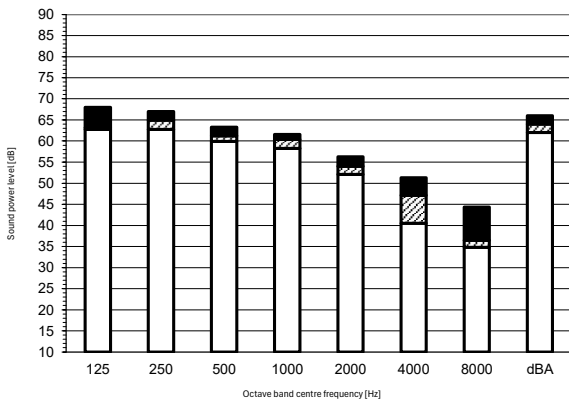

Heating mode

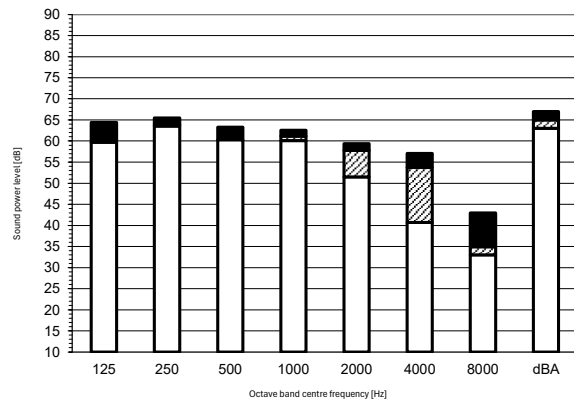

Legend

- A Scale
- B Fan speed: High
- C Fan speed: Medium
- D Fan speed: Low

Notes

- 1) dBA = A-weighted sound power level (A scale according to IEC).
- 2) Reference acoustic power 0 dB = -10E-6 μW
- 3) Measured according to ISO 3744.

Cooling				Total dB
A	B	C	D	
dBA	66,0	64,0	62,0	

Heating				Total dB
A	B	C	D	
dBA	67,0	65,0	63,0	

4D156983

9 Sound data

9 - 2 Sound Pressure Spectrum

9

FXFN40B

Cooling mode

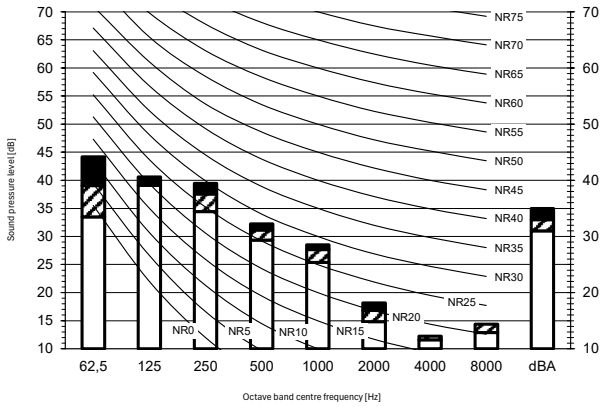

Heating mode

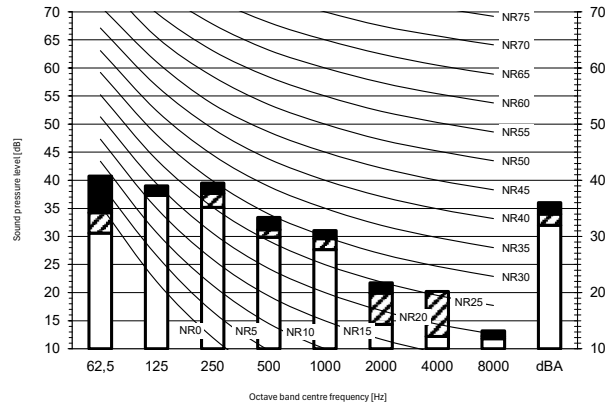

Legend

dBA = A-weighted sound pressure level (A scale according to IEC).

- A Scale
- B Fan speed: High
- C Fan speed: Medium
- D Fan speed: Low

Location of microphone

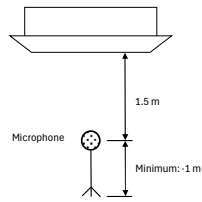

Notes

- 1) Operating conditions: power source 220-240 V/220 V 50/60 Hz; JIS standard
- 2) Background noise already taken into account.
- 3) Operating noise varies depending on operation and ambient conditions.
- 4) The operation noise measuring method is in accordance with JISC9612.
- 5) Measuring location: anechoic chamber

Cooling		Total dB			
A	B	C	D		
dBa	35,0	33,0	31,0		

Heating		Total dB			
A	B	C	D		
dBa	36,0	34,0	32,0		

4D156976

FXFN50B

Cooling mode

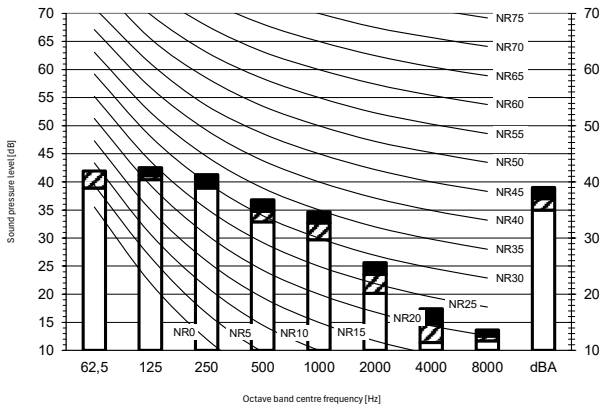

Heating mode

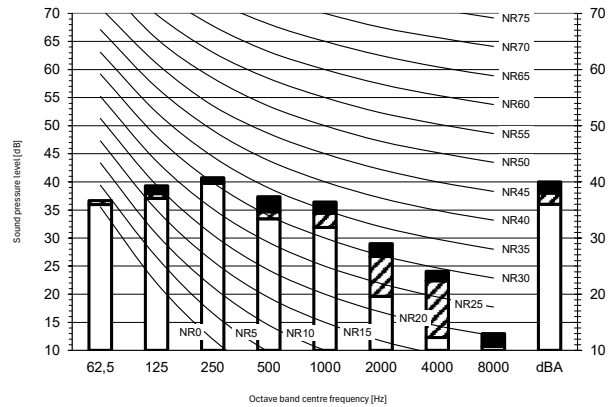

Legend

dBA = A-weighted sound pressure level (A scale according to IEC).

- A Scale
- B Fan speed: High
- C Fan speed: Medium
- D Fan speed: Low

Location of microphone

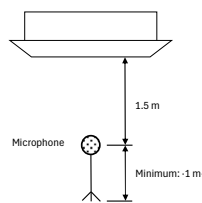

Notes

- 1) Operating conditions: power source 220-240 V/220 V 50/60 Hz; JIS standard
- 2) Background noise already taken into account.
- 3) Operating noise varies depending on operation and ambient conditions.
- 4) The operation noise measuring method is in accordance with JISC9612.
- 5) Measuring location: anechoic chamber

Cooling		Total dB			
A	B	C	D		
dBa	39,0	37,0	35,0		

Heating		Total dB			
A	B	C	D		
dBa	40,0	38,0	36,0		

4D156977

9 Sound data

9 - 2 Sound Pressure Spectrum

FXFN63B

Cooling mode

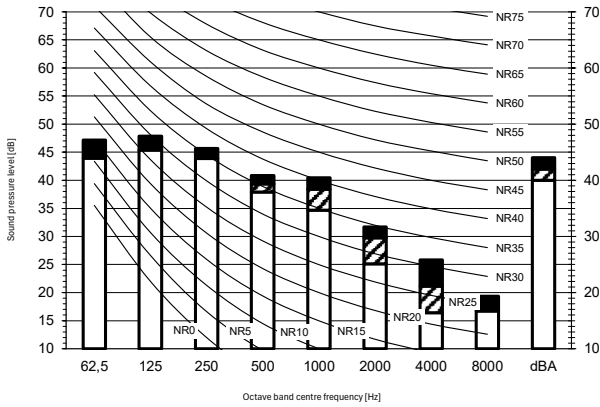

Heating mode

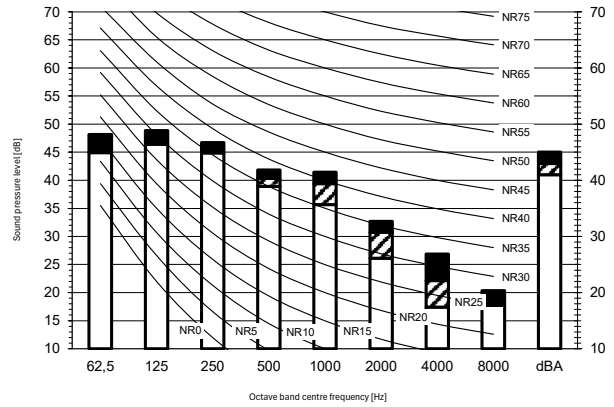

Legend

dBA = A-weighted sound pressure level (A scale according to IEC).

- A Scale
- B Fan speed: High
- C Fan speed: Medium
- D Fan speed: Low

Location of microphone

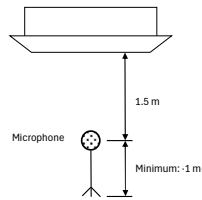

Notes

- 1) Operating conditions: power source 220-240 V/220 V 50/60 Hz; JIS standard
- 2) Background noise already taken into account.
- 3) Operating noise varies depending on operation and ambient conditions.
- 4) The operation noise measuring method is in accordance with JISC9612.
- 5) Measuring location: anechoic chamber

Cooling		Total dB			
A	B	C	D		
dBa	44,0	42,0	40,0		

Heating		Total dB			
A	B	C	D		
dBa	45,0	43,0	41,0		

4D156978

FXFN80B

Cooling mode

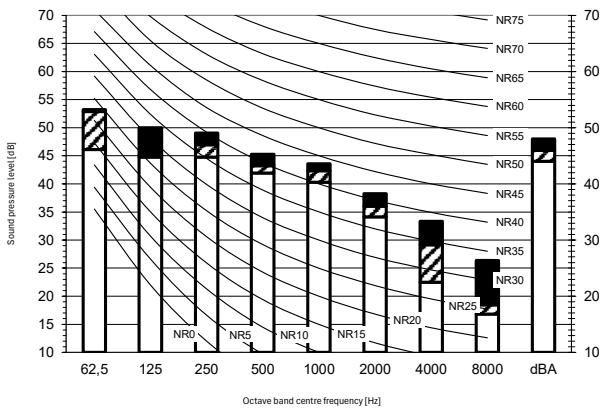

Heating mode

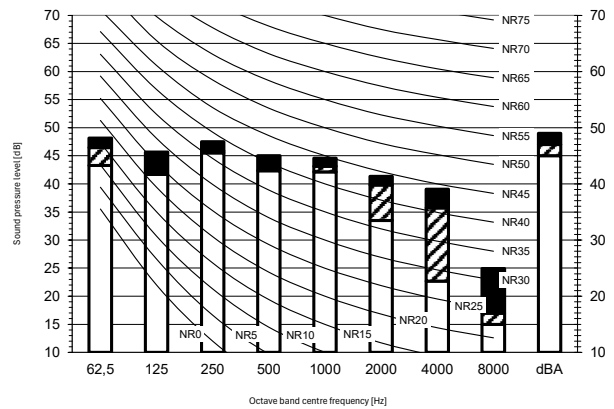

Legend

dBA = A-weighted sound pressure level (A scale according to IEC).

- A Scale
- B Fan speed: High
- C Fan speed: Medium
- D Fan speed: Low

Location of microphone

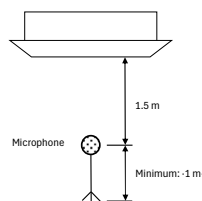

Notes

- 1) Operating conditions: power source 220-240 V/220 V 50/60 Hz; JIS standard
- 2) Background noise already taken into account.
- 3) Operating noise varies depending on operation and ambient conditions.
- 4) The operation noise measuring method is in accordance with JISC9612.
- 5) Measuring location: anechoic chamber

Cooling		Total dB			
A	B	C	D		
dBa	48,0	46,0	44,0		

Heating		Total dB			
A	B	C	D		
dBa	49,0	47,0	45,0		

4D156979

10 Air flow patterns

10 - 1 Air flow pattern - Cooling and Heating

10

FXFN40B

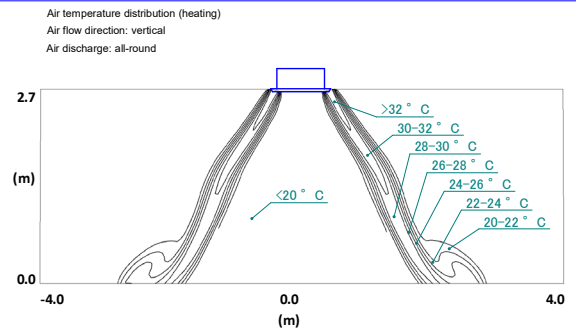
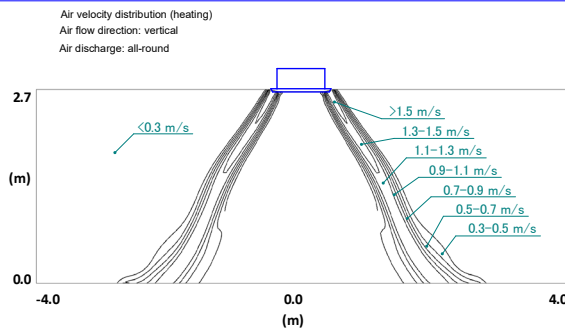
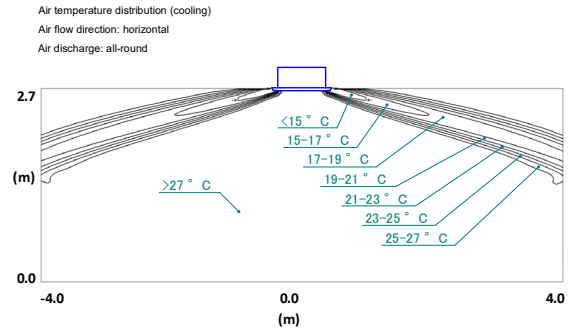
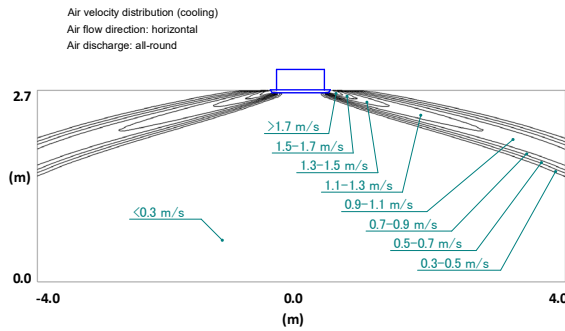

FXFN50B

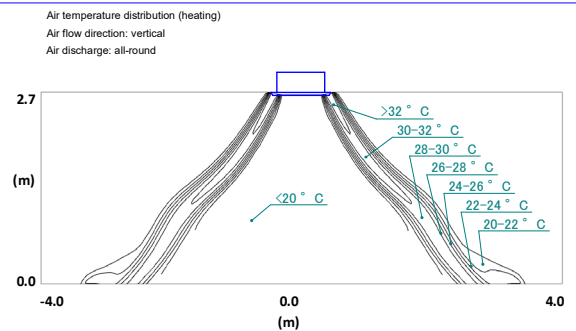
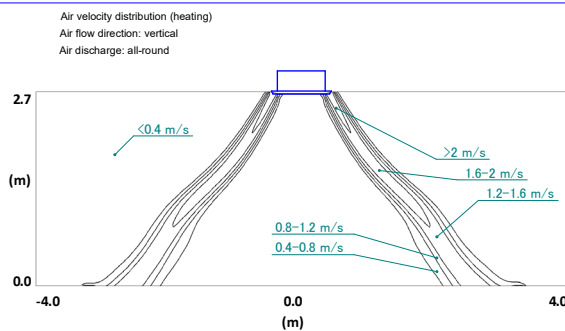
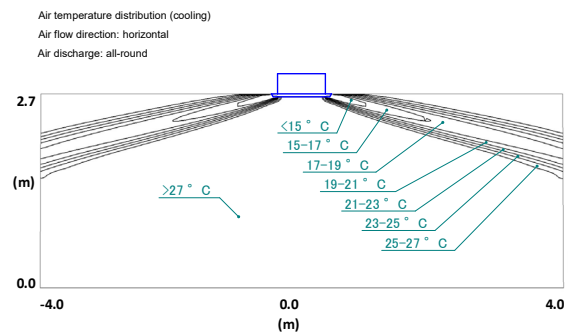
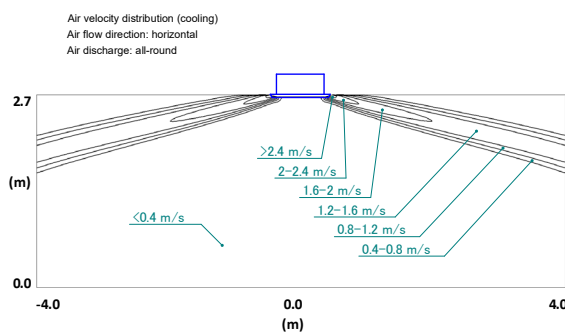

10 Air flow patterns

10 - 1 Air flow pattern - Cooling and Heating

FXFN63B

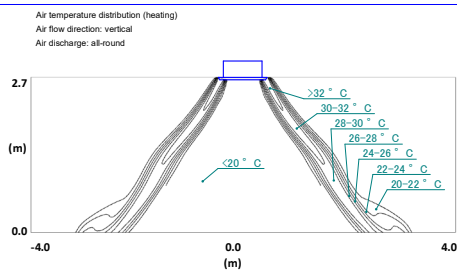
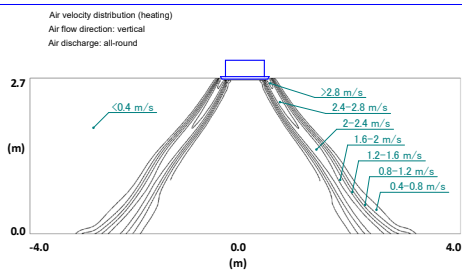
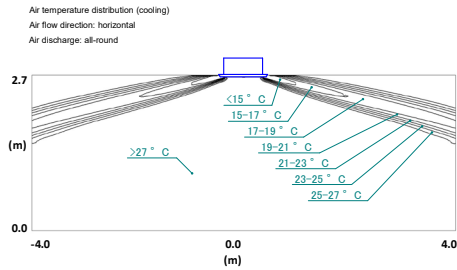
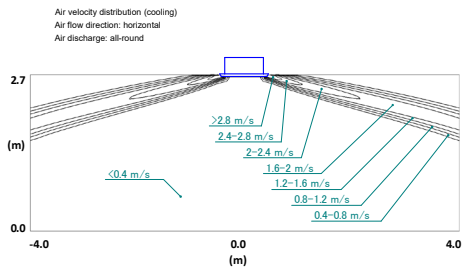

3D157227

FXFN80B

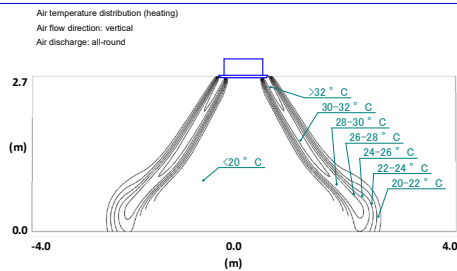
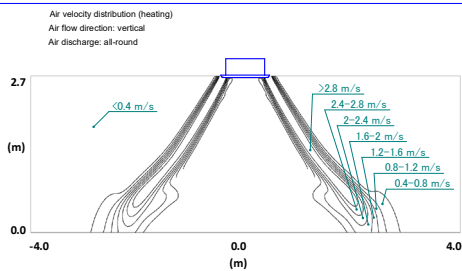
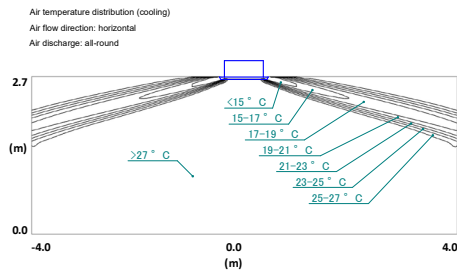
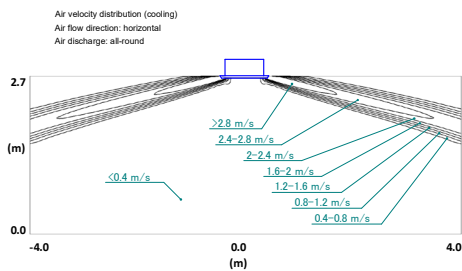

4D157228

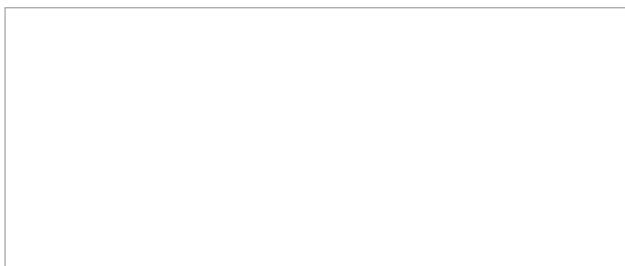

EEDEN25

04/2025



The present leaflet is drawn up by way of information only and does not constitute an offer binding upon Daikin Europe N.V. Daikin Europe N.V. has compiled the content of this leaflet to the best of its knowledge. No express or implied warranty is given for the completeness, accuracy, reliability or fitness for particular purpose of its content and the products and services presented therein. Specifications are subject to change without prior notice. Daikin Europe N.V. explicitly rejects any liability for any direct or indirect damage, in the broadest sense, arising from or related to the use and/or interpretation of this leaflet. All content is copyrighted by Daikin Europe N.V.