

9 Wiring diagrams

9 - 1 Wiring Diagrams - Single Phase

3MXF52A9

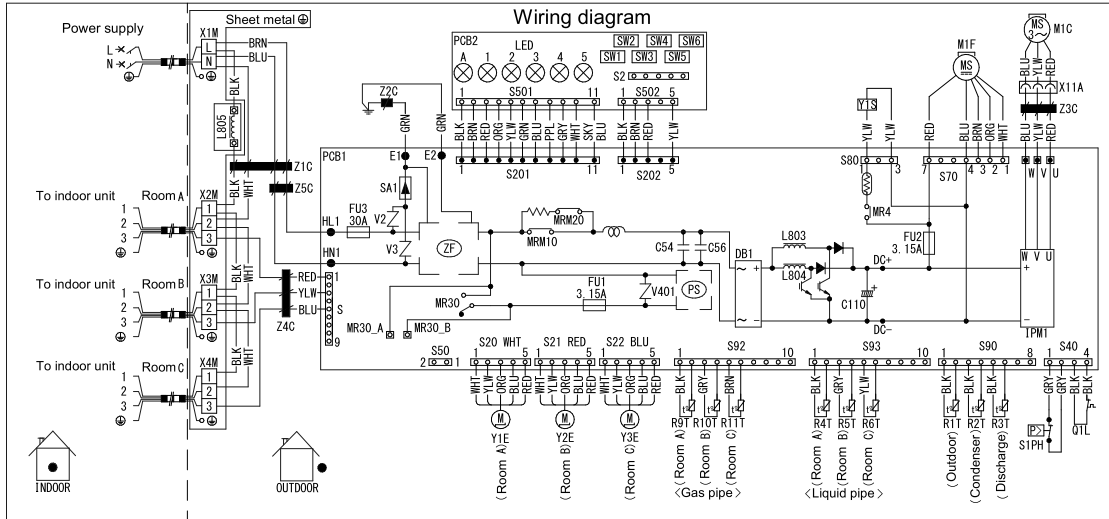

C110, C54, C56	Capacitor	PS	Switching power supply	ZF	Noise filter
DB1	Diode bridge	Q1L	Overload protector	S, S2-S502	Connector
FU1, FU2, FU3	Fuse	R1T-R11T	Thermistor	U, V, W	Connector
IPM1	Intelligent power module	SA1	Surge arrester	X11A, MR30, A, MR30, B	Connector
L803, L804, L805	Reactor	S1PH	High pressure switch	Field wiring	
LED1-5, LEDA	Light-emitting diode	SW1-SW6	Switch	Screw terminal	
M1C	Compressor motor	V2, V3, V401	Varistor	Connector	
MIF	Fan motor	X1M-X4M	Terminal strip with earth terminal	GRY: grey	SKY BLU: sky blue
MRM10, MRM20	Magnetic relay	Y1E-Y3E	Electronic expansion valve coil	BLU: blue	ORG: orange
MR4, MR30	Magnetic relay	Y1S	Reversing solenoid valve coil	BRN: brown	PPL: purple
PCB1, PCB2	Printed circuit board	Z1G-Z5C	Ferrite core	GRN: green	RED: red
					SKY BLU: sky blue
					WHT: white
					YLW: yellow
					3D123866-1A

3D123866A

3MXF68A9

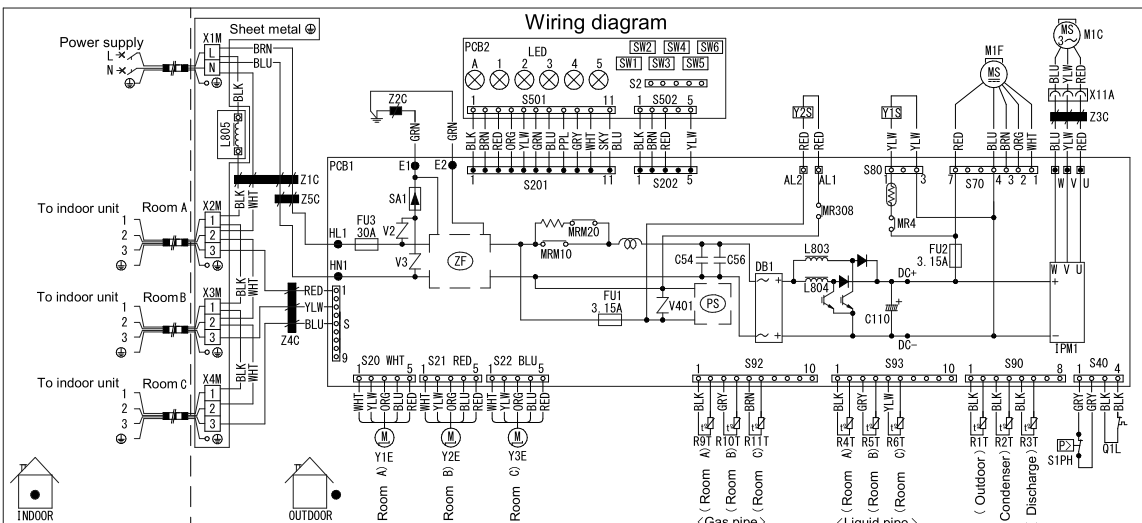

C110, C54, C56	Capacitor	PS	Switching power supply	ZF	Noise filter
DB1	Diode bridge	Q1L	Overload protector	S, S2-S502	Connector
FU1, FU2, FU3	Fuse	R1T-R11T	Thermistor	U, V, W	Connector
IPM1	Intelligent power module	SA1	Surge arrester	X11A, AL1, AL2	Connector
L803, L804, L805	Reactor	S1PH	High pressure switch	Field wiring	
LED1-5, LEDA	Light-emitting diode	SW1-SW6	Switch	Screw terminal	
M1C	Compressor motor	V2, V3, V401	Varistor	Connector	
MIF	Fan motor	X1M-X4M	Terminal strip with earth terminal	GRY: grey	SKY BLU: sky blue
MRM10, MRM20	Magnetic relay	Y1E-Y3E	Electronic expansion valve coil	BLU: blue	ORG: orange
MR4, MR308	Magnetic relay	Y1S	Reversing solenoid valve coil	BRN: brown	PPL: purple
PCB1, PCB2	Printed circuit board	Z1G-Z5C	Ferrite core	GRN: green	RED: red
					SKY BLU: sky blue
					WHT: white
					YLW: yellow
					3D123861-1B

3D123861B